

Unici  

---

TO BE  
complementi di design





# Unici

---

## TO BE

complementi di design

*unique designer items*

# La perfezione non esiste ma è vero che esiste la perfezione dell'unicità.

*Gabriella Bellino*

Noi di Elite To Be siamo un'azienda specializzata nella ricerca di soluzioni uniche nella produzione di complementi di design e arredamenti particolari per il vivere contemporaneo.

Con le nostre tre divisioni di prodotto, combinabili fra loro, ci rivolgiamo ai progettisti e agli operatori di settore desiderosi di distinguere la propria proposta progettuale, sia nell'ambito residenziale che negli arredamenti horeca.

Riteniamo che l'autenticità e l'originalità sia un valore da difendere in arredamento, per questo proponiamo complementi e soluzioni di design realizzati artigianalmente con materiali unici e naturali.

*Perfection doesn't exist but the  
perfection of uniqueness it's true*

*Our designer products are conceived to stand the test of time, always incarnating the real luxury of today: being authentically true to one's self.*

*Craftsmanship and high quality finishes make our pieces of furniture unique and give them a distinctive character; not just objects, but items that create special atmospheres, specifically designed to best suit contemporary lifestyles as well as the future trends of home-living.*

*Elite To Be's accessories express the excellence of Made in Italy furniture, where customer desires are shaped in the name of quality.*



## Unicità in arredo

*Uniqueness in furniture*

### Unici TO BE

#### Complementi unici nei materiali e nelle forme

Singolari nelle forme, i nostri complementi d'arredo sono prodotti e rifiniti artigianalmente con legni, metalli, e pietre di pregio.

Gli Unici To Be sono pezzi naturali irripetibili, ideali per arredare in modo esclusivo sia gli spazi domestici che professionali.

#### *Unique design and materials accessories*

*Unique in their forms, our furnishing accessories are handcrafted and finished with precious woods, metals and stones.*

*The Unici To Be are unrepeatable natural pieces, ideal for furnishing both domestic and professional spaces in an exclusive way.*

### Wine TO BE

#### Arredamenti per enoteche e librerie del vino

La passione per il buon vino è parte fondamentale della nostra storia, per questo produciamo specifici accessori e arredamenti per enoteche e per locali di degustazione.

Con le nostre librerie del vino offriamo un modo originale e privilegiato di esibire e conservare le tue bottiglie di valore.

#### *Furnishings for wine bars and wine stores*

*The passion for good wine is a fundamental part of our history, which is why we produce specific accessories and furnishings for wine bars and wine tasting rooms.*

*With our wine libraries we offer an original and privileged way to exhibit and preserve your valuable bottles.*

### Modulo TO BE

#### Una nuova idea di parete attrezzata

Modulare, semplice, intercambiabile e polifunzionale, queste le caratteristiche che contraddistinguono la nostra soluzione di parete attrezzata.

Modulo To Be soddisfa l'attuale bisogno di arredare la "casa da vivere" in modo funzionale ed esteticamente ricercato.

#### *A new idea of modular wall system*

*Modular, simple, interchangeable and multifunctional, these are the characteristics that distinguish our equipped wall solution.*

*Modulo To Be satisfies the current need to furnish the "home to live in" in a functional and sophisticated way.*



## Materiali e finiture

- I legni massicci \_ 12
- Il rattan \_ 27
- Il ferro acidato \_ 34
- I massellati \_ 39
- L' argilla biocompatibile \_ 55
- La fusione di alluminio \_ 73
- La radice di teak \_ 93
- I mosaici \_ 101
- Le polveri \_ 151
- Le finiture diamantate \_ 161
- La ceramica \_ 170
- Scheda colori \_ 180

## Materials and finishes

- Solid Woods* \_ 12
- Rattan* \_ 27
- Etched iron* \_ 34
- Solid Wood Framed* \_ 39
- Clay* \_ 58
- Cast Aluminum* \_ 73
- Teak roots* \_ 93
- Mosaic* \_ 101
- Powder Coating* \_ 150
- Diamond finishes* \_ 161
- Ceramic* \_ 170

- Dimensions* \_ 180
- Color Finishes* \_ 184

**Tavoli e  
Sedie \_10**

*Tables and  
Chairs \_ 10*

Ala \_14  
Giulia \_18/37  
Ala Jr B \_20  
Ala Jr A \_24  
Giuly \_27  
Dasar \_28  
Byron \_30  
Dasar Jr \_36  
Trog sedia \_48/49  
Trog Jr \_46/47  
Trog \_44  
Noa sedia \_60/61  
Noa tavolo \_50/57  
Noa Jr \_62  
Kadra \_66  
Kalonga \_68

**Tavolini e  
Sgabelli \_10**

*Coffee Tables  
and Stools \_70*

Taolin \_65  
Kaalta \_64  
Otto Tall & Low \_74  
Otto \_76  
Al \_78/79  
Fil De Fer \_80  
Ketil \_84  
Tris \_86  
Hug \_88  
Kross \_90  
Kobe \_92  
Igloo \_96/97

**Madie e  
Credenze\_98**

*Sideboards \_98*

Stratos \_102  
Convivium Slim \_115  
Convivium Bold \_119

**Illuminazione\_120**

*Lighting \_120*

Baloon \_123  
Lenti \_124  
Nest \_127  
Gami \_130  
Tuli \_133  
Ek lamo \_134  
La Lun \_137  
Arboj \_139  
Goblet \_140

**Librerie\_142**

*Bookshelves \_142*

Hakkasan\_144  
Napala \_154  
Doda \_157  
Mooie \_162

**Complementi e  
Accessori\_166**

*Accessories\_166*

Rainbow \_168  
Cardo \_169  
La Lun \_171  
Gong \_172  
Terno \_175  
The Family \_176  
La Vit \_179

# il valore dell'unicità

Carattere forte e deciso, funzionalità, elegante ricercatezza: una fusione armonica di elementi che definisce la personalità del brand Elite To Be.

Lo stile Elite To Be si definisce attraverso linee rigorose che esaltano i materiali di pregio, legnami nobili e metalli ricercati, le raffinate finiture, la sapiente manifattura e l'attenta cura dei dettagli. Creazioni pensate per superare le logiche dello spazio e per evolversi nel tempo, per consentire all'individuo di essere autenticamente se stesso e vivere le proprie scelte in libertà.

Oggetti unici ed originali, dall'anima inconfondibile, vere icone del vivere contemporaneo, perfetto connubio tra forma e materia.



## *Unique designer items*

*Strong personality, functionality, sophisticated elegance: a well-balanced fusion of elements defines both the character of Elite To Be's brand and the furnishing accessories for living areas from the Unici To Be line.*

*The Unici to Be line of designer products perfectly embodies Elite To Be's idea of style: a precise design that enhance the characteristics of high quality materials, the use of hard woods and sophisticated metals, the refined handcrafted finishes, the skillful manufacturing process and a close attention to details.*

*These leaving area furnishing accessories are designed to evolve beyond the way space is conceived today in order to allow individuals to be authentically themselves and to freely live a life of their choice.*

*Unique and original furniture items, with a sophisticated design and an unmistakable soul: true icons of contemporary living, the perfect union of form and matter.*





# Tavoli e sedie



Elite to Be propone una serie di coordinati di tavoli e sedie dal design moderno ed originale.

Nei tavoli, alle basi in metallo con linee geometriche, vengono abbinati piani in diversi materiali: dal legno massiccio all'argilla, dal massellato al legno impiallacciato.

I coordinati di tavoli e sedie Unici To Be sono oggetti unici nelle forme e nelle finiture, ideali per essere inseriti con stile in contesti moderni o più tradizionali.

## *Tables and chairs*

*Discover the unique design of Elite To Be's tables and chairs made of natural materials*

*Elite To Be's line of handcrafted tables features a modern and original design.*

*Our handmade tables consist of metal table bases with a geometric design combined with table tops made of natural materials, such as: solid wood, clay, solid wood edges and wood veneer.*

*The coordinated chairs and solid wood tables are one-of-a-kind items with a unique design and finish, ideals for both modern and traditional interiors.*



# legno massiccio, materia viva

In Elite To Be, i modelli Dasar, Trog, Ala e Noa, il piano dei tavoli è realizzato con materiali di elevato pregio: il legno massiccio di suar, teak e rovere.

La caratteristica principale dei tavoli in massiccio è quella di essere ricavato da un unico tronco. Ogni elemento di legno massiccio nasce perciò come pezzo unico da una singola pianta e presenta quindi le naturali fessure e crepe proprie del tronco.

Altra peculiarità del massiccio è il fatto che esso sia "materia viva", nel tempo, in relazione alle escursioni termiche e all'umidità in ambiente,

il legno si muove accentuando o modificando la propria forma e le fessurazioni.

È un fenomeno del tutto naturale che altresì certifica il pregio e il valore del legno impiegato per la realizzazione dei tavoli.

## *Solid wood, a living material*

*Elite To Be's Dasar, Trog, Ala and Noa table all feature wood tops made with some of the finest materials available: Teak, Suar and Oak solid wood.*

*All of our solid wood tables are made from a single trunk. Originating from a single tree, every solid wood item displays the natural splits and cracks of a trunk and is, therefore, unique.*

*Another characteristic feature of solid wood is that it is a living material: through time, it moves in reaction to the changes in temperature and humidity of the environment, thus changing both its shape and cracks.*

*This is a natural phenomenon that certifies the quality and value of the wood used to make our designer tables.*

## Suar

Il Suar, chiamato in Oriente anche albero della pioggia (rain tree, è un legno molto apprezzato per la sua grande resistenza; esteticamente è caratterizzato da accentuate differenze cromatiche tra l'alburno e il durame nonché dalle classiche venature.

Le crepe sono intrinseche di questo legno, le cui ampie sezioni sono scelte proprio per avere evidenti spaccature lungo vena, che divengono esse stesse peculiarità uniche dell'arredo.

## Suar

*Suar, also called rain tree in the East*

*(rain tree), is a wood much appreciated for its great resistance; aesthetically it is characterized by accentuated chromatic differences between the sapwood and the heartwood as well as by the classic veins.*

*The cracks are intrinsic to this wood, whose large sections are chosen precisely to have evident cracks along the grain, which themselves become unique features of the furniture.*

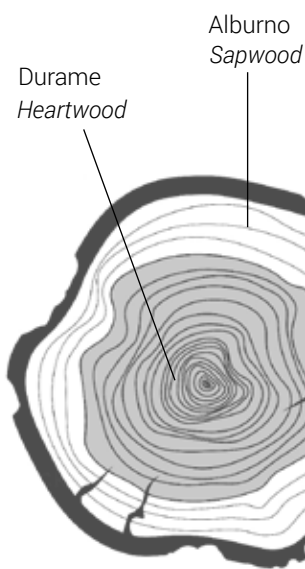

## Teak

Il legno di Teak proviene dall'Asia meridionale, dall'India all'Indonesia fino al Vietnam.

È un legno molto durevole, insensibile alle muffe e agli insetti, oltre ad essere molto resistente alle intemperie non richiede manutenzione nel tempo.

Il nostro Teak viene trattato con una finitura totalmente naturale (non chimica né coprente, eseguita con l'olio presente nel legno e con una cera neutra per migliorare l'impermeabilità all'acqua, o ad ogni altro liquido).

## Teak

*Teak wood comes from South Asia, from India to Indonesia up to Vietnam.*

*It is a very durable wood, insensitive to mold and insects, as well as being very resistant to bad weather, it does not require maintenance over time.*

*Our Teak is treated with a totally natural finish (not chemical or opaque), performed with the oil present in the wood and with a neutral wax to improve its impermeability to water, or any other liquid.*



## Rovere

Il rovere è una quercia molto longeva che può raggiungere e addirittura superare i 300 anni di vita.

In Italia è presente soprattutto nelle vallate alpine e prealpine e nell'Appennino.

Nel rovere l'alburno è giallastro e il durame bruno, ha fibra dritta anche se irregolare e tessitura media, è un legno molto duro, difficile da scalfire e resistente alle intemperie e agli agenti atmosferici.

Rappresenta la scelta ideale per la costruzione di mobili massicci, molto di tendenza per arredamenti con stile pulito e minimalista.

## Oak

*Oak is a very long-lived oak that can reach and even exceed 300 years of life.*

*In Italy it is present above all in the Alpine and Pre-Alpine valleys and in the Apennines.*

*In oak, the sapwood is yellowish and the heartwood brown, it has a straight even if irregular fibre and medium texture, it is a very hard wood, difficult to scratch and resistant to inclement weather and atmospheric agents.*

*It represents the ideal choice for the construction of solid furniture, very trendy for furnishings with a clean and minimalist style.*



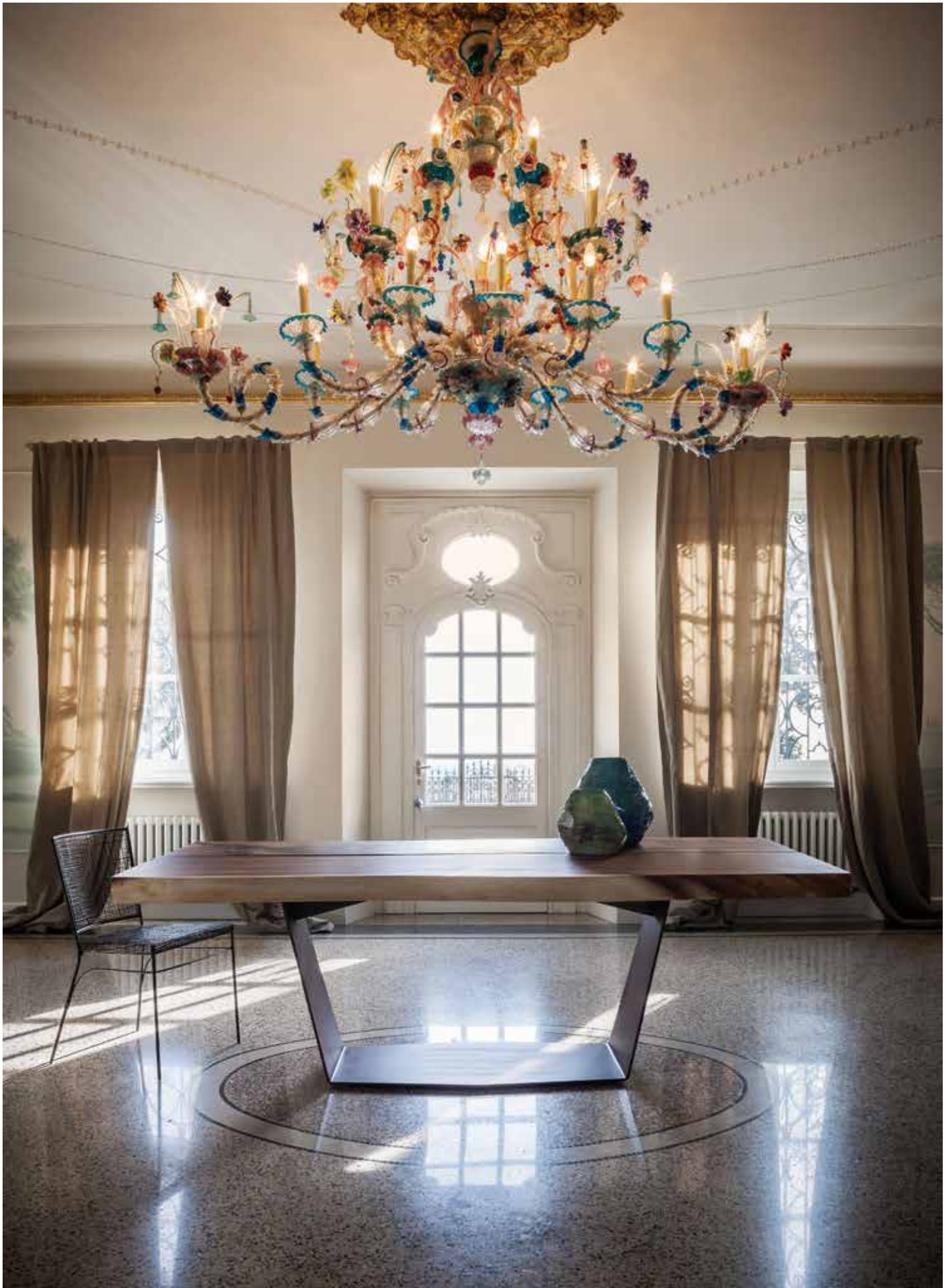

- \_ Tavolo Ala
- \_ Sedia Giulia
- \_ Vasi Cardo

TAVOLI E SEDIE  
TABLES AND CHAIRS

- \_ table Ala
- \_ chair Giulia
- \_ vase Cardo



## \_Ala

Tavolo con base in metallo e piano in legno massiccio  
Table with metal base and solid wood top

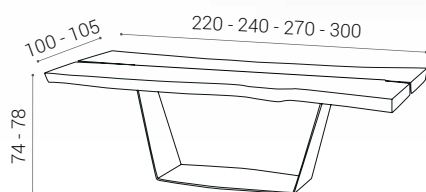

### \_Misure

#### \_dimensions

220 x 100 -105 x H.74/78  
240 x 100 -105 x H.74/78  
270 x 100 -105 x H.74/78  
300 x 100 -105 x H.74/78

### \_Finiture

#### \_Finishes

Basamento  
Basement



Piano  
Top



Suar  
H. 8-9 cm



Rovere / Oak  
H. 5 cm

Elegante ed imponente, Ala è un tavolo in legno massiccio con struttura in metallo che si distingue per il suo vigore e la sua matericità, perfetto come protagonista della scena all'interno di ogni ambiente.

*Majestic and elegant, Ala is a solid wood table with a metal structure that stands out for its tactile texture and strength, the perfect centerpiece of any interior.*

*This model is also available in its Junior versions, ideal for modern dining rooms and trendy venues.*

\_ ALA Tavolo  
\_ ALA Table









### Giulia

Sedia in fil di ferro  
Iron wire chair

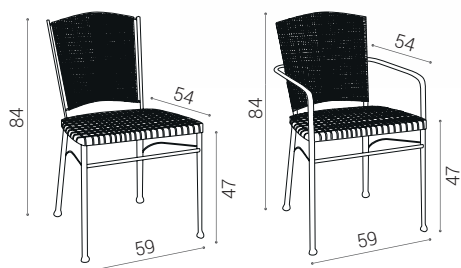

**\_Finiture**

Ferro  
antracite

**\_Finishes**

Iron  
Anthracite

Giulia è una sedia in metallo dove la struttura in tondino pieno e l'intreccio in fil di ferro si uniscono per ottenere un complemento unico nel panorama delle sedie contemporanee di design.

*Giulia is a metal chair consisting of an iron rod structure and an iron wire weave that combine in a unique furniture item with no equal in the contemporary chair design scene.*





## Ala junior B

Tavolo con base in metallo

Parte della collezione Ala Junior, questo tavolo da pranzo moderno è un esempio eclatante della sorprendente coesistenza tra rigore geometrico e materiali contrastanti.

Le gambe sono modellate da una lastra di metallo che si piega per creare una base trapezoidale, supportando senza sforzo la parte superiore composta dal piano rettangolare o romboidale. Essenziale e moderno, questo tavolo contemporaneo ha un carattere giocosamente dinamico che completerà un sofisticato interno minimalista.

Table with metal base

*Belonging to the Ala Junior collection, this modern dining table is a striking example of the stunning coexistence of geometric precision and contrasting materials.*

*The legs consist of a metal plate bent to create a trapezoid-shaped base that effortlessly support a rectangular or diamond shape table top. Modern and with a clean style, this contemporary design table has a playful and dynamic attitude that perfectly suits sophisticated minimalist interiors.*

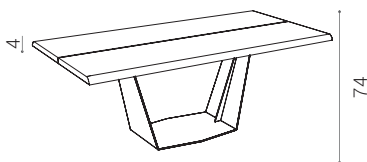

Piano tavolo massiccio  
*Solid wood table top*  
\_Misure\_Dimensions

160 x 85 x H.74  
180 x 85 x H.74  
200 x 93 x H.74

^Finiture\_Finishes

Basamento  
*Basement*



Piano  
*Top*



Suar  
H. 4 cm

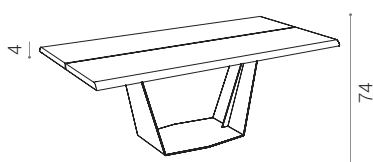

Piano tavolo massellato  
*Solid wood edge table top*  
\_Misure\_Dimensions

160 x 80 x H.74  
180 x 90 x H.74  
200 x 100 x H.74

\_Finiture\_Finishes

Basamento  
*Basement*



Piano  
*Top*



Piano tavolo squadrato  
*Square Table Top*  
\_Misure\_Dimensions

160 x 90 x H.73  
180 x 90 x H.73  
200 x 90 x H.73

\_Finiture\_Finishes

Basamento  
*Basement*



Piano  
*Top*

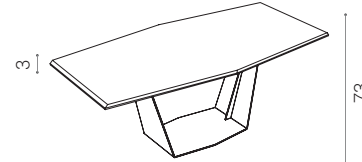

Piano tavolo "romboidale"  
*"Diamond" shape table top*  
\_Misure\_Dimensions

160 x 90(64 x H.73  
180 x 90(72 x H.73  
200 x 100(80) x H.73

\_Finiture\_Finishes

Basamento  
*Basement*



Piano  
*Top*





- \_ ALA Junior tavolo
- \_ GIULY sedia in rattan
- \_ LENTI lampadario
- \_ RAINBOW vasi in ceramica

- \_ *table ALA Junior B*
- \_ *chair GIULY*
- \_ *light LENTI*
- \_ *vase RAINBOW*





\_ALA Junior B tavolo

\_ALA Junior B table







- \_ ALA Junior A tavolo
- \_ GIUKY sedia
- \_ NEST lampadario
- \_ Ala Junior A table
- \_ chair Giuly
- \_ light Nest \_

TAVOLI E SEDIE  
TABLES AND CHAIRS



Ala junior A

Tavolo con base in metallo e piano massellato

Table with metal base and solid wood edge top

Il più piccolo dei tavoli Ala Junior, questo pezzo è un tavolo di design ideale per un moderno angolo colazione, un ingresso industriale o un locale di tendenza. Il tavolo in legno e ferro presenta un piano disponibile in massiccio, massellato, impiallacciato o argilla sostenuto da una sorprendente base in metallo.

The smallest of the Junior tables collection is ideal for a modern breakfast nook, an industrial style hall or a trendy venue. Made of iron and wood, this model is available with table tops in solid wood, in solid wood edge, in veneered wood and clay supported by a stunning metal base. The contrast between the metal finish of the base and the warmth of the wood is extremely eye-catching.

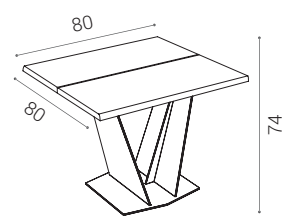

Piano tavolo massiccio  
Solid wood table top

\_Misure\_ Dimensions  
80 x 80 x H.74

\_Finiture\_ Finishes

- Basamento  
Basement (A) (B) (P)  
Piano  
Top (Suar) H.4 cm

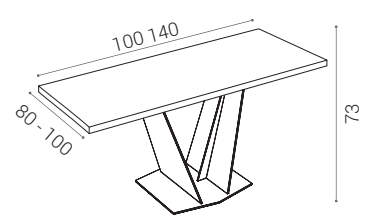

Piano tavolo squadrato  
Wood veneered table top

\_Misure\_ Dimensions  
140 x 80 x H.73  
100 x 100 x H.73

\_Finiture\_ Finishes

- Basamento  
Basement (A) (B) (P)  
Piano  
Top (F) (G)



## L'intreccio in rattan

Le sedute e gli schienali di Giuly sono realizzate in rattan.

Si tratta di una fibra naturale ricavata dalla lavorazione di alcune specie di palme rampicanti del sud-est asiatico.

Oltre all'innegabile raffinatezza e al fascino esotico, questo materiale ha anche una serie di vantaggi pratici.

Molto resistente, è al contempo leggero e resistente alla muffa, per questo ideale anche per arredi da esterno riparato.

Grazie alla sua malleabilità, si presta ad essere intrecciato per dar forma a suppellettili e mobili di estrema eleganza.

Utilizzarlo nell'ambito dell'arredamento si rivela anche una scelta etica e responsabile. Parliamo infatti di un materiale biodegradabile e a crescita molto rapida.



## Woven rattan

*The seat and the backrest of the Giuly model are made with rattan.*

*Rattan is a natural fiber obtained from certain species of climbing palms that grow in South-east Asia.*

*In addition to its sophisticated and exotic charm, this material offers also a series of practical advantages. It is extremely durable, light and mold-resistant, making it also ideal for sheltered outdoor furniture.*

*It is also very flexible and can be easily shaped into extremely elegant furniture and accessories.*

*The use of rattan in the furniture sector is also an ethically responsible choice. In fact, we are talking about a fast-growing plant that is also biodegradable.*

## TAVOLI E SEDIE TABLES AND CHAIRS



\_Giuly

Sedia in ferro e rattan  
Rattan and iron chair

Giuly è una sedia realizzata artigianalmente in rattan con struttura in tondino di ferro.

Innegabile la raffinatezza e il fascino di questa sedia di design che è contemporaneamente resistente e leggera, quindi ideale anche per arredi da esterno riparato.

Scegliere una Giuly in rattan si rivela anche una scelta etica e responsabile perché parliamo di un materiale ecocompatibile e a crescita molto rapida.

*Giuly is a rattan handcrafted chair with an iron rod structure..*

*With an undeniable refined and charming design, this chair is at the same time durable and light and, therefore, also suitable for outdoor use.*

*Choosing a Giuly rattan chair is also an ethically responsible choice since it is made with a fast-growing biodegradable material.*

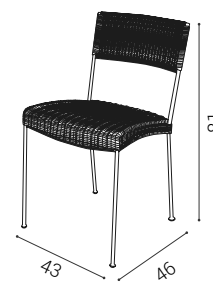
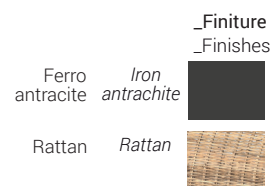

# TAVOLI E SEDIE TABLES AND CHAIRS

Il tavolo in suar **Dasar**, anche grazie alla struttura portante in ferro, esprime la solidità e la forza materica profondamente radicate nella visione di Elite To Be.

Il piano è costituito da due semipiani in legno massiccio suar o rovere dai contorni irregolari. Ideale come tavolo da degustazione vino, questo complemento trova la sua perfetta collocazione in enoteche e spazi importanti di ristorazione.

**Dasar** è un pezzo di innegabile impatto pensato per decorare ambienti dalla raffi nata ricercatezza.

*Made from Suar wood, our **Dasar** table, also thanks to its iron supporting frame, fully embodies the concepts of solidity and strength of materials that lie at the heart of Elite To Be's vision.*

*The table top consists of two irregularly-shaped solid wood half tops made from Suar or Oak.*

*Ideal as a wine tasting table, this furniture item is ideal for wine shops or dining venues.*

***Dasar** is a undoubtedly a striking product, specially conceived for sophisticated and refined interiors.*

## \_Dasar

Tavolo con basi in metallo e piano in legno massiccio  
*Table made of metal and solid wood*

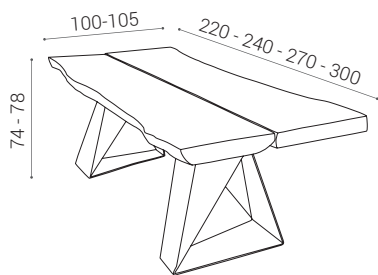

**\_Misure \_Dimensions**  
220 x 100-105 x H.74/78  
240 x 100-105 x H.74/78  
270 x 100-105 x H.74/78  
300 x 100-105 x H.74/78

### \_Finiture \_Finishes

Basamento  
*Basement*



Piano  
*Top*



Suar  
H. 8-9 cm



Rovere *Oak*  
H. 5 cm

Tavolo Dasar \_  
Lampada Baloon \_  
*table Dasar \_  
light Baloon \_*







## Byron

Sedia in fusione di alluminio  
*Cast aluminum chair*

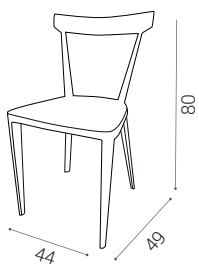

**\_Finiture**  
**\_Finishes**  
Ⓐ Ⓑ Ⓒ







La sedia da cucina di design Byron è un pezzo singolo in fusione di alluminio.

Realizzata con la tecnica artigianale della "colata in terra" ogni sedia risulta essere un complemento di design unico e irripetibile, mai uguale a se stesso.

È disponibile in alluminio lucido o spazzolato, nelle finitur diamantate e a polveri.

*Byron is a designer kitchen chair consisting of single cast aluminum piece..*

*Crafted with the sand casting technique, each chair is a unique and one-of-a-kind designer item.*

*It is available in the following finishes: polished or brushed aluminum, nickel, bronze or lead, satin or diamond brass.*

TAVOLI E SEDIE  
TABLES AND CHAIRS



## L'acidatura del ferro

L'unicità dei complementi Elite To Be è data anche dalle finiture adottate per i componenti in metallo, tra queste l'acidatura è particolarmente sofisticata e conferisce un'estetica singolare agli arredi.

Si tratta di una finitura artigianale che consiste nell'ossidazione del ferro naturale, che viene successivamente stabilizzata per garantirne la durata nel tempo.

In Elite To Be la lavorazione avviene mediante l'immersione del pezzo nella soluzione ossidante che crea un'acidatura omogenea con contrasti tenui, le diverse tonalità date dall'acido sfumano, conferendo un effetto armonioso di colori che variano dal marrone scuro, al verde al grigio.

## *Etched iron furniture*

*Part of the reason why Elite To Be's designer metal furniture is unique is up to the type of finishes used. Among them, acid etching is particularly sophisticated and allows for an extremely peculiar look. In this handcrafted finishing technique iron is first oxidized and then stabilized in order to ensure its durability over time.*

*At Elite To Be, the process is carried out by dipping the piece in an oxidative solution in order to obtain a uniform etching effect with light differences in hue.*

*The etching process gives each metal furniture piece an extremely well-balanced variety of colours with shades ranging from dark brown to green and grey.*

### **Finiture uniche**

L'acidatura del ferro è una lavorazione fatta manualmente, quindi suscettibile a differenze di effetto visivo tra un pezzo e l'altro.

Questa particolarità determina l'unicità di ogni lavorazione: il valore aggiunto insito nell'artigianalità della finitura.

### **La scelta**

Sul ferro è possibile ottenere molteplici colorazioni, dall'effetto caldo e intenso:

Ferro bronzato  
Ferro brunito  
Effetto corten

### *Unique finishes*

Iron etching is a finishing process carried out by hand; as a result, every item looks different from the other.

The characteristics that make each piece unique testify of the extra value inherent in handcrafted products.

### *The choice*

it is possible to obtain multiple colors, with a warm and intense effect:

Burnished  
Bronzed  
Corten





## Dasar Junior

Tavolo con base in metallo  
Table with metal basement

I tavoli Dasar Junior, grazie alle basi in metallo, all'attento dimensionamento e all'utilizzo di diversi tipi di materiali per la realizzazione dei piani, permettono di portare tavoli dallo stile contemporaneo nelle vostre sale da pranzo, rendendole moderne ed esclusive.

*The Dasar junior line consists of carefully sized tables with metal bases and table tops made from different materials; this range of products brings to your home contemporary design tables, giving a modern and exclusive flavor to your interiors.*

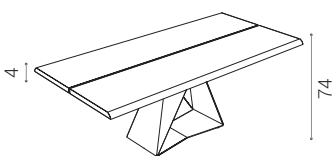

Piano tavolo massiccio  
Solid wood table top

**\_Misure \_Dimensions**

160 x 85 x H.74  
180 x 85 x H.74  
200 x 93 x H.74

**\_Finiture \_Finishes**

Basamento Basement (A) (B) (P)  
Piano Top (E) Suar H. 4 cm

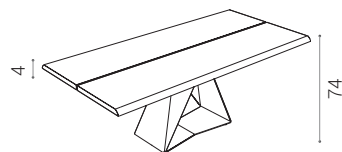

Piano tavolo masellato  
Solid wood edge table top

**\_Misure \_Dimensions**

160 x 80 x H.74  
180 x 90 x H.74  
200 x 100 x H.74

**\_Finiture \_Finishes**

Basamento Basement (A) (B) (P)  
Piano Top (E)

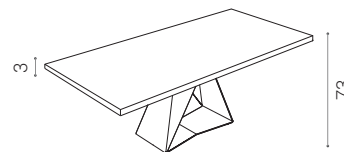

Piano tavolo squadrato  
Square table top

**\_Misure \_Dimensions**

100 x 100 x H.73  
140 x 80 x H.73  
160 x 90 x H.73  
180 x 90 x H.73  
200 x 90 x H.73

**\_Finiture \_Finishes**

Basamento Basement (A) (B) (P)  
Piano Top (F) (G)

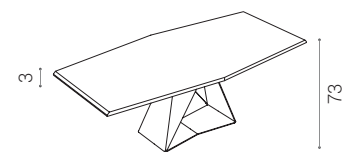

Piano tavolo "romboidale"  
"Diamond shape" table top

**\_Misure \_Dimensions**

140 x 80 (62) x H.73  
160 x 80 (64) x H.73  
180 x 90 (72) x H.73  
200 x 100 (80) x H.73

**\_Finiture \_Finishes**

Basamento Basement (A) (B) (P)  
Piano Top (G)



DASAR Junior tavolo \_  
GIULIA sedia \_  
LA LUN lampade \_

DASAR Junior table \_  
GIULIA chair \_  
LA LUN light \_

TAVOLI E SEDIE  
TABLES AND CHAIRS



Esempi di tavolo Dasar Junior  
realizzati con piano in suar  
massiccio e piano in argilla  
bio-compatibile.

*Examples of Dasar Junior table  
made with solid suar top and  
biocompatible clay top.*

## I massellati

La massellatura è una particolare lavorazione dei tavoli dove il piano in agglomerato viene bordato con uno spessore di legno massello.

Nei tavoli Dasar, Ala, Trog e Noa della serie Junior, questa lavorazione viene effettuata prestando la massima attenzione nel mantenere reale l'effetto estetico del legno massiccio, con le sue naturali irregolarità anche nei bordi. La massellatura permette quindi di ottenere piani meno soggetti all'umidità e quindi più stabili nel tempo, il tutto senza rinunciare al reale piacere estetico e tattile del legno massiccio.

## Solid wood edges

*The solid wood edge is a particular manufacturing process in which a wood composite panel is covered and bonded with solid wood*

*In our Dasar, Ala, Trog and Noa Jr table versions, this process is done with great care so that the final product looks as if it was made of solid wood only, with its natural irregular grain also on the edges.*

*The solid wood edge technique allows for tables that are more stable and damp resistant, while maintaining at the same time the real look and feel of solid wood..*

Esempi di tavolo Dasar Juinior  
realizzato con piano in argilla  
bio-compatibile.

*Examples of Dasar Junior table  
made with bio-compatible clay  
top.*





TAVOLI E SEDIE  
TABLES AND CHAIRS



## dalla Natura l'ispirazione per le nostre forme ...nasce Trog

La Natura con le sue molteplici forme di vita, animale e vegetale, è la fonte d'ispirazione per la progettazione dei nostri complementi d'arredo.

Nel pensare i supporti per i tavoli della linea Trog, ci siamo rifatti alle forme slanciate dei volatili cercando di imitarne la dinamicità e la leggerezza estetica.

Uno sforzo che ha pagato, dando vita ad una linea di tavoli originali e sofisticati, arredi unici per portare l'idea di Natura nei vostri ambienti.

## *Shapes inspired by Nature... Trog is born.*

*Nature, with its multitude of animal and plant life forms, is the source of inspiration for the design of our furnishing accessories*

*In conceiving the supporting structures for the Trog line of tables, we took inspiration from the sleek shapes of birds and we tried to aesthetically reproduce their dynamism and lightness.*

*An effort that paid off by bringing to life a line of tables with an original and sophisticated design: unique furniture to bring the idea of Nature to interiors.*

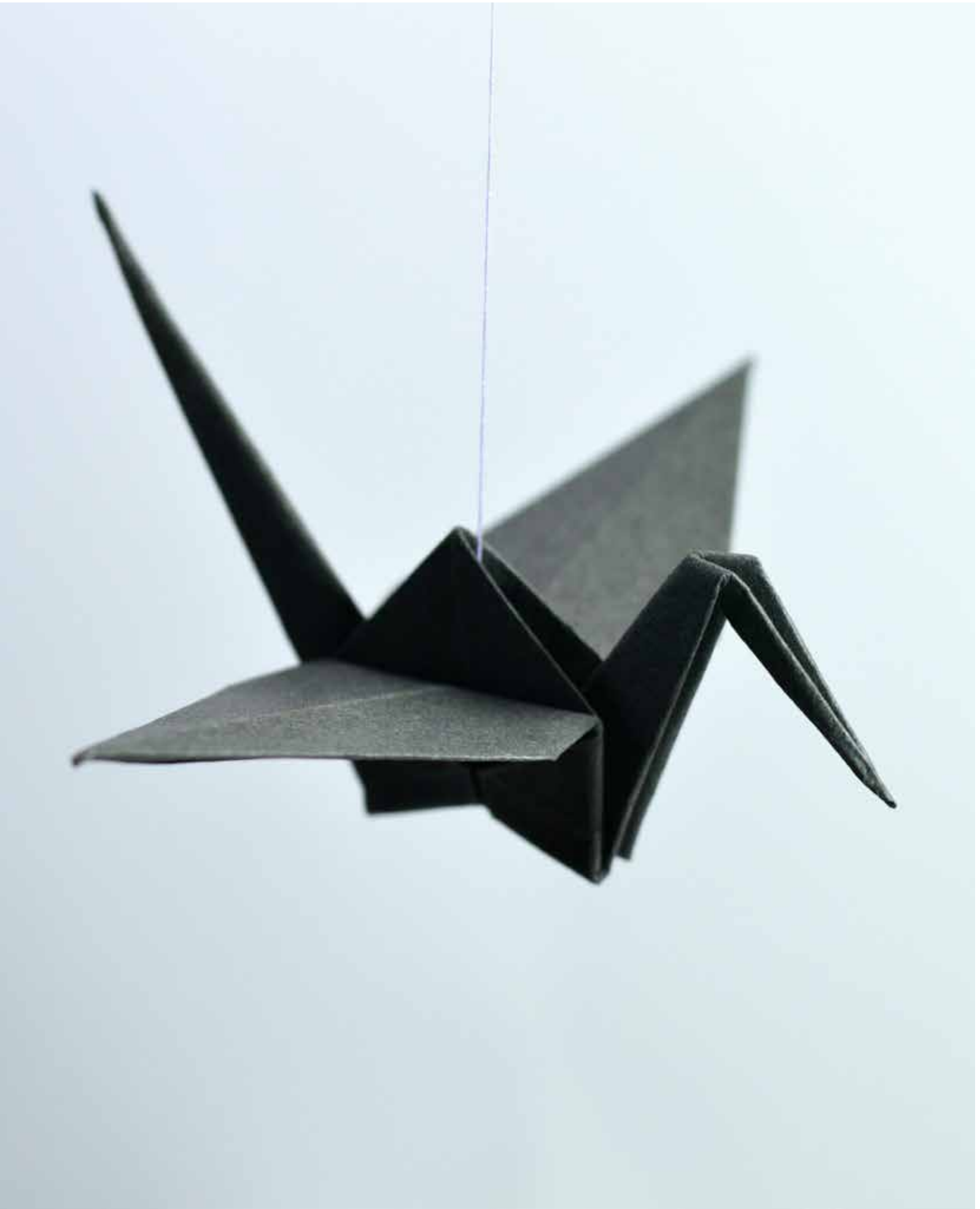



\_ TROG tavolo  
\_ EKFLAMO Lampada

\_ TROG table  
\_ EKFLAMO light

## \_Trog

Tavolo con basi in metallo e piano in legno massiccio  
*Rustic table made of metal and solid wood*

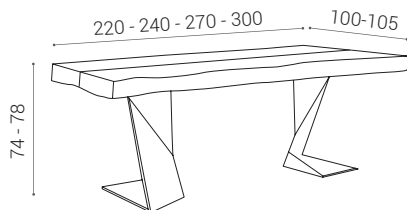

### \_Misure\_Dimensions

220 x 100 -105 x H.74/78  
240 x 100 -105 x H.74/78  
270 x 100 -105 x H.74/78  
300 x 100 -105 x H.74/78

### \_Finiture\_Finishes

Basamento  
*Basement*



Piano  
*Top*



Suar  
H. 8-9 cm



Rovere *Oak*  
H. 5 cm

Ispirato alle linee slanciate e scattanti degli uccelli, il tavolo artigianale Trog si compone di due semipiani in legno massiccio, sostenuti da gambe dalle forme dinamiche, scolpite nel metallo e rifinite a mano.

*Inspired by the sleek and agile shape of birds, Trog is our handcrafted table made of two solid wood half tops supported by legs with a dynamic design, made of forged metal and finished by hand.*



TAVOLI E SEDIE  
TABLES AND CHAIRS



## \_Trog Junior

Tavolo con base in metallo  
*Table with metal base*

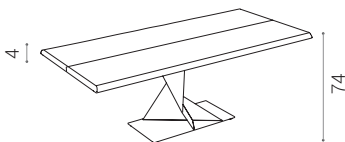

Piano tavolo massiccio  
*Solid wood top*

**\_Misure\_Dimensions**

160 x 85 x H.74  
180 x 85 x H.74  
200 x 93 x H.74

**\_Finiture\_Finishes**

Basamento  
*Basement* (A) (B) (P)  
Piano  
*Top* Suar  
H. 4 cm

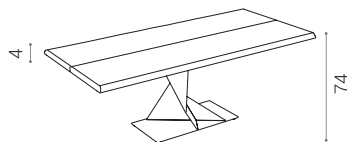

Piano tavolo massellato  
*Solid wood edge top*

**\_Misure ^Dimensions**

160 x 80 x H.74  
180 x 90 x H.74  
200 x 100 x H.74

**\_Finiture\_Finishes**

Basamento  
*Basement* (A) (B) (P)  
Piano  
*Top* (E)

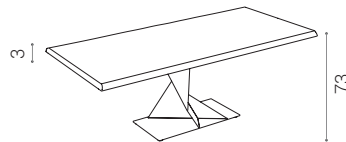

Piano tavolo squadrato  
*Squared table top*

**\_Misure ^Dimensions**

100 x 100 x H.73  
140 x 80 x H.73  
160 x 90 x H.73  
180 x 90 x H.73  
200 x 90 x H.73

**\_Finiture\_Finishes**

Basamento  
*Basement* (A) (B) (P)  
Piano  
*Top* (F) (G)

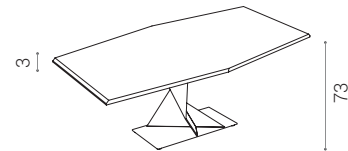

Piano tavolo "rombo"  
*"Diamond shape" table top*

**\_Misure\_Dimensions**

140 x 80 (62 x H.73)  
160 x 80 (64 x H.73)  
180 x 90 (72 x H.73)  
200 x 100 (80) x H.73

**\_Finiture\_Finishes**

Basamento  
*Basement* (A) (B) (P)  
Piano  
*Top* (G)



TAVOLI E SEDIE  
TABLES AND CHAIRS







Progettata per essere abbinata al tavolo Trog questa sedia con struttura in ferro taglio laser, presenta la eco\_pelle anticata - testa di moro o nero - come elemento distintivo nel rivestimento della seduta e dello schienale.

*Designed to be combined with Trog tables, this chair is characterized by a laser-cut iron structure and seat and backrest covered in antiqued leather, available in black and dark brown colors.*

**\_Finiture\_** *Finishes*

Struttura *\_Metal frame* (A) (B) (P)

**Seduta e schienale**

*\_Seat and back padding*

Eco\_pelle nera

Eco\_leather black



Eco\_pelle anticata testa di moro

Eco\_aged leather dark brown



## Trog

Sedia con struttura in metallo e seduta in eco\_pelle

*Metal frame and leather chair*

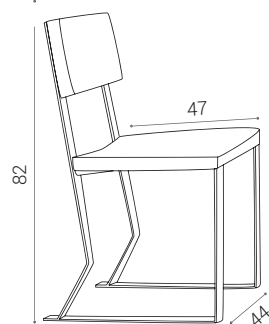

TAVOLI E SEDIE  
TABLES AND CHAIRS

## Noa\_il segno del tempo

Il fascino del vissuto,  
oggetti con una storia , con  
qualcosa da raccontare:  
questo è il valore di un  
tavolo Noa realizzato con  
legno di teak riciclato.

Il legno riciclato è unico  
perché porta con se i segni  
originali del suo vissuto che  
non è mai uguale a quello  
degli altri.

## Noa\_the sign of the time

*The charm of the lived,  
objects with a history, with  
something to tell:  
this is the value of a  
**Noa** table made with  
recycled teak wood.*

*Recycled wood is unique  
because it carries with it the original marks  
of it's experience which  
is never the same as that  
of the others.*

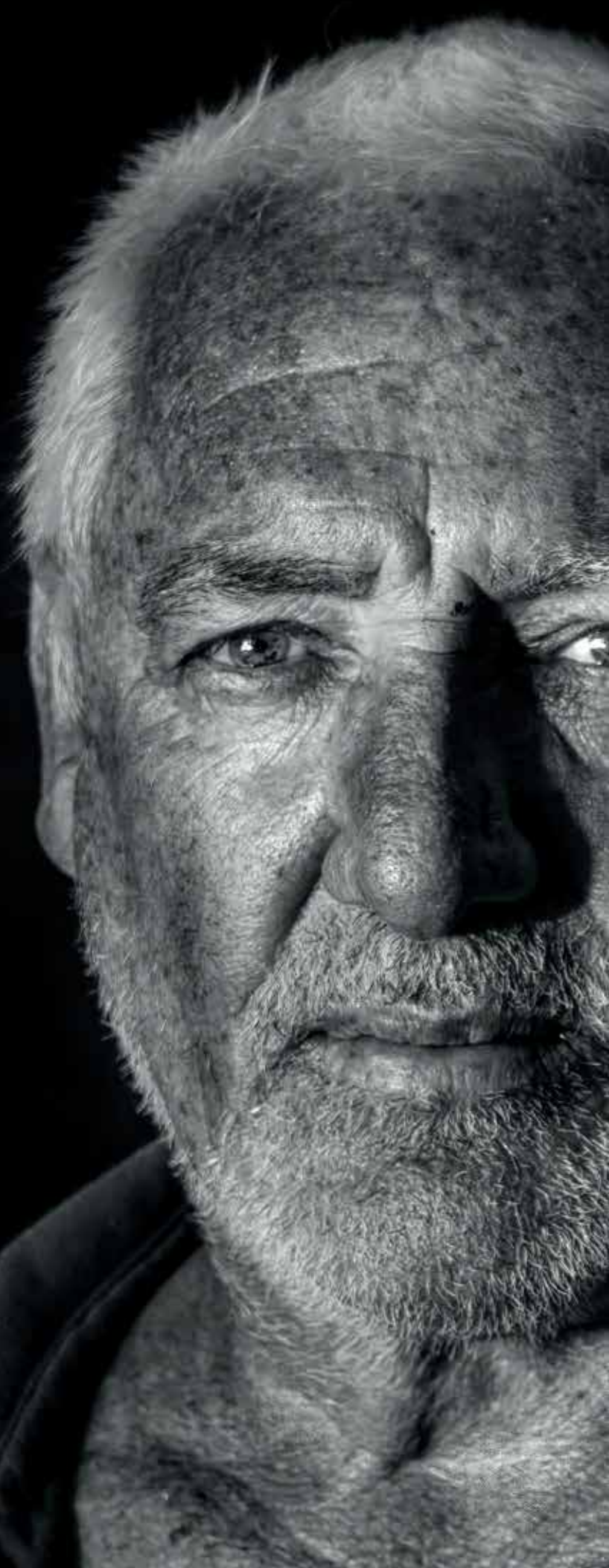



TAVOLI E SEDIE  
TABLES AND CHAIRS

NOA è un tavolo moderno composto da un piano in Teak e gambe in fusione di alluminio.

Dalle linee eleganti e pulite NOA è disponibile anche nella versione con piano in teak riciclato che dona le suggestioni del materiale vissuto, ricco di storia e di carattere.

NOA è disponibile anche nelle versioni Junior con piani impiallacciati o in argilla biocompatibile

*NOA is a table made with Teak top and cast aluminum legs, designed for the modern living room.*

*With its clean and elegant design, NOA is also available in a version with a recycled Teak table top: an item with the charm and character of time-worn material, a piece of furniture with a story to tell.*

*NOA is also available in its Junior versions with table tops made of veneered wood or bio-compatible clay.*

## Noa

Tavolo con piano in teak e gambe in fusione di alluminio

*Table with Teak table top and cast aluminum legs*

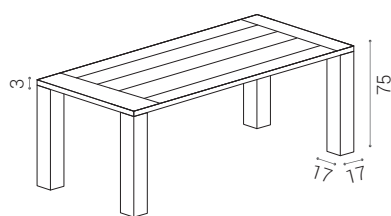

Piano Tavolo  
Table Top

**\_Misure\_** **\_Dimensions\_**  
220 x 110 x H.75  
240 x 120 x H.75  
270 x 120 x H.75

Gambe in alluminio  
Aluminium Legs

**\_Misure\_** **\_Dimensions\_**  
17 x 17 x 71

**\_Finiture\_** **\_Finishes\_**

Gambe Legs



Piano  
Top



Teak  
Teak



Teak Riciclato  
Recycled Teak

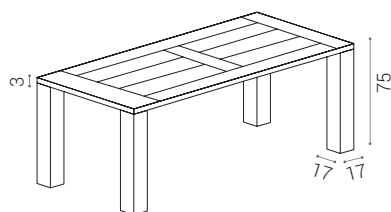

Piano Tavolo  
Table Top

**\_Misure\_** **\_Dimensions\_**  
220 x 110 x H.75  
240 x 120 x H.75  
270 x 120 x H.75

Gambe in alluminio  
Aluminium Legs

**\_Misure\_** **\_Dimensions\_**  
17 x 17 x 71

**\_Finiture\_** **\_Finishes\_**

Gambe Legs



Piano  
Top



Teak  
Teak



Teak Riciclato  
Recycled Teak





## Noa

Tavolo con piano squadrato e gambe  
in fusione di alluminio

*Table with Teak table top and cast  
aluminum legs*

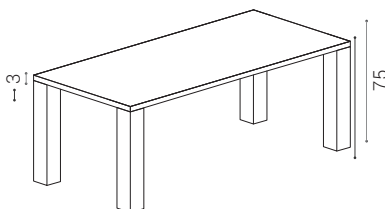

Piano Tavolo  
*Table top*

**\_Misure \_Dimensions**  
200 x 100 x H.75  
180 x 90 x H.75  
160 x 90 x H.75  
140 x 140 x H 75

Gambe in alluminio  
*Aluminium legs*

**\_Misure \_Dimensions**  
17 x 17 x H 71  
15 x 15 x H 71  
12 x 12 x H 71  
17 x 17 x H 71

**\_Finiture**

*\_Finishes*

Gambe  
*Legs*



Piano  
*Top*





NOA tavolo con piano in  
argilla biocompatibile \_

*NOA table with  
biocompatible Clay top \_*

TAVOLI E SEDIE  
TABLES AND CHAIRS







NOA tavolo top in argilla\_  
NOA sedia \_  
BALOON lampadario \_  
STRATOS madia in mosaico\_  
IGLOO sgabello in alluminio \_  
RAINBOW ciotole in ceramica \_

*NOA table with clay top\_*  
*NOA chair \_*  
*BALOON chandelier \_*  
*STRATOS sideboard with mosaic doors\_*  
*IGLOO aluminium stool \_*  
*RAINBOW ceramic vase \_*



## L'argilla biocompatibile

Tra i materiali utilizzati negli UniciTo Be, l'argilla riveste una particolare rilevanza nella direzione dell'ecosostenibilità e della salute.

Si tratta di una bio-malta a base d'acqua che non contiene cemento, calce, resine epossidiche e altre sostanze nocive per l'uomo e l'ambiente.

La bio-malta a base d'argilla è studiata appositamente per il settore del mobile e viene applicata completamente a mano, conferendo imperfezioni e imprecisioni che sono il valore aggiunto del risultato estetico finale.

Disponibile in sei diverse colorazioni, l'argilla viene impiegata per la realizzazione dei piani dei tavoli.

### *Biocompatible Clay*

*Among the materials used in our Unici To Be line, clay stands out for being one of the most safe, healthy and environment-friendly.*

*This water-based eco-mortar does not contain cement, lime, epoxy resins or other hazardous and noxious substances potentially harmful for the health and the environment.*

*Clay-based eco-mortar is developed specifically for the wood-furniture industry and is completely hand-applied; as a result, clay furniture accessories are characterized by handcrafting imperfections that add value to the final aesthetic result.*

*Available in six different colors, clay is used for the table tops of the Dasar, Ala, Trog and Noa jr models, as well as for the panels of the Modulo To Be equipped wall.*





TAVOLI E SEDIE  
TABLES AND CHAIRS

La sedia Noa rappresenta l'unione di due degli elementi fondamentali che legano i prodotti Elite To Be.

Teak o teak silver sono sostenuti dallo schienale e dalle due gambe in fusione di alluminio disponibili in varie finiture.

Noa è una sedia per cucine di design che ben si presta ad essere collocata anche in altri contesti abitativi.



*The Noa Chair is the result of the perfect union between two fundamental elements that characterize Elite To Be's range of products.*

*The seat is two-legged piece, made from teak or silver teak wood, supported by a cast aluminum backrest with legs; this model is available in different finishes.*

*Although originally designed for kitchens, Noa also perfectly suits other parts of the house.*

## Noa

Sedia in legno e alluminio  
Teak and cast aluminum

### \_Finiture\_Finishes

Metallo\_Metal



Legno\_Wood



Teak Silver  
Teak Silver

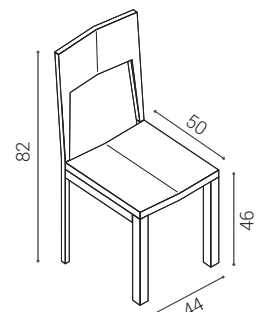

TAVOLI E SEDIE  
TABLES AND CHAIRS



**\_Noa Junior**

Tavolo con piano squadrato e  
gambe in metallo  
*Square top table with metal legs*

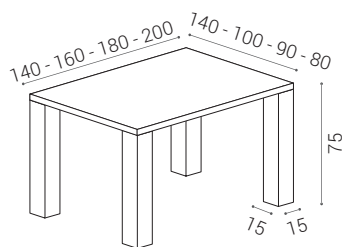

Piano tavolo  
*Table top*

Gambe  
*Table Legs*

**\_Misure**  
*\_Dimensions*

**\_Misure**  
*\_Dimensions*

140 x 140 x H.75  
140 x 80 x H.75  
160 x 90 x H.75  
180 x 90 x H.75  
200 x 100 x H.75

15 x 15 x 71

**\_Finiture**  
*\_Finishes*

Gambe  
*Legs*



Piano  
*Table top*





- \_ TAOLIN tavolino alto
- \_ KAALTA sgabello
- \_ LIBRERIA DEL VINO portabottiglie

- \_ TAOLIN high table
- \_ KAALTA stool
- \_ LIBRERIA DEL VINO wine racks







**\_Taolin**

Tavolino alto in legno e metallo  
*High table in wood and metal*

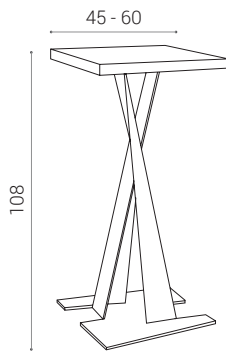

**Piano Tavolo**  
45 x 45 x H.108  
45 x 60 x H.108  
60 x 60 x H.108

**\_Finiture**

**\_Finishes**

Basamento (B) (P)  
*Basement*

Piano Tavolo (B) (F) (G)  
*Table top*  
Suar  
*Suar*  
Rovere  
*Oak*



**\_Kaalta**

Sedia alta in legno e metallo  
*Metal and wood stool*

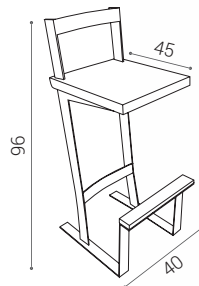

**\_Finiture**

**\_Finishes**

Base (B) (P)  
*Frame*

Seduta (B) (F) (G)  
*Seat*  
Suar  
*Suar*  
Rovere  
*Oak*

Caratteristica peculiare della serie Kaalta è il design. Disponibili in legno massiccio di rovere, suar o argilla.



TAVOLI E SEDIE  
 TABLES AND CHAIRS



**\_Kadra**

Sedia in legno e metallo  
 Chair in wood and metal

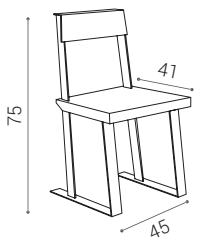

**\_Finiture** *\_Finishes*

Base *Frame*



Seduta *Seat*



Rovere *Rovere*



(D) \* solo su Richiesta Speciale

\* *Only on Special request*

DASAR tavolo \_  
KADRA sedia \_  
LA LUN lampadario \_

*DASAR table \_  
KADRA chair \_  
LA LUN chandelier \_*



- \_ DASAR tavolo
- \_ KALONGA panca

- \_ *DASAR table*
- \_ *KALONGA bench*





TAVOLI E SEDIE  
TABLES AND CHAIRS

## \_Kalonga

Panca in legno e metallo

*Bench in wood and metal*

### \_Finiture \_Finishes

Base (B) (P)  
Frame

Seduta  
Seat



Suar  
Suar



Rovere  
Rovere

(F) (G)

(D) Solo su richiesta

*\* Only on Special request*

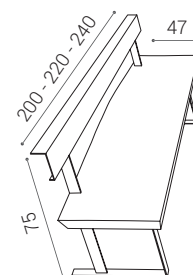

# Tavolini e sgabelli

Le forme basiche e lineari e l'utilizzo di materiali unici con finiture ricche sono le caratteristiche che contraddistinguono la linea di tavolini e sgabelli Elite To Be.

Elementi unici per arredare in modo sofisticato i vostri ambienti.

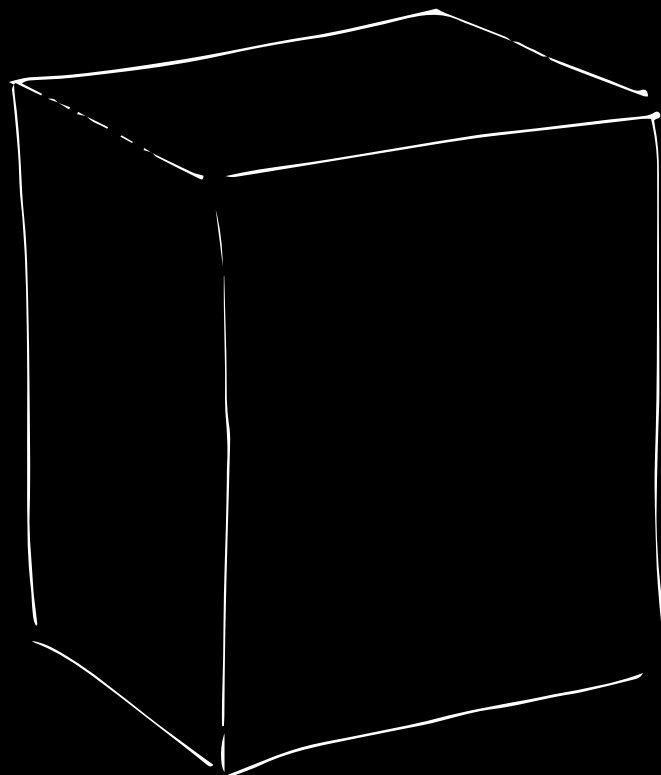

# *Coffee tables and stools*

*Elite To Be's line of coffee tables and stools is characterized by a simple and linear design and using finely finished unique materials.*

*Unique furniture items for sophisticated interiors.*

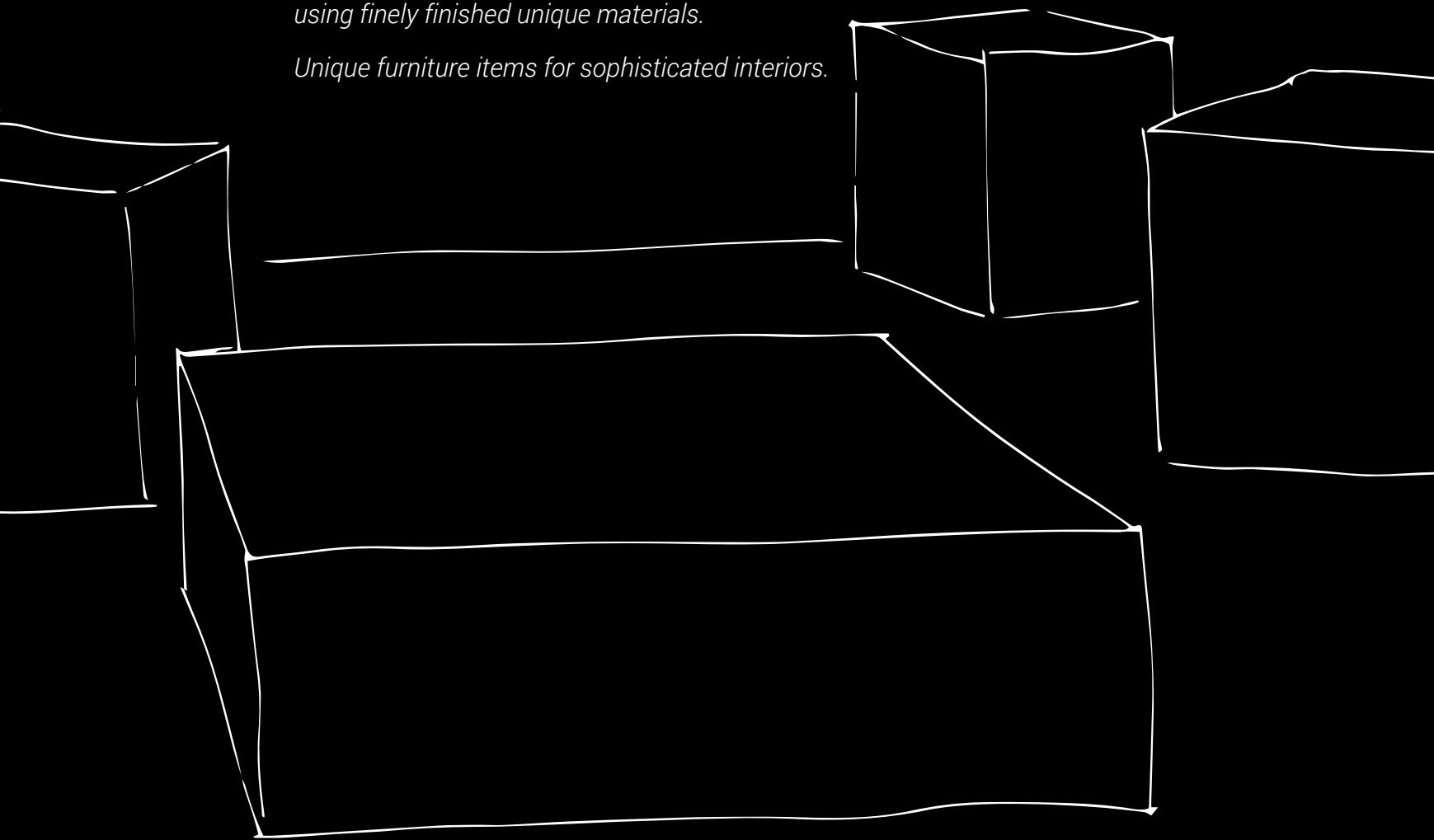





## La fusione d'alluminio

Per la produzione dei complementi in fusione di alluminio, in Elite To Be viene adottato il metodo della "colata in terra" che è la classica e più antica lavorazione di fonderia.

Partendo dal modello, costruito in legno, alluminio o resina, si produce lo stampo utilizzando una terra speciale, chiamata terra da fonderia.

Di seguito il metallo fuso viene colato nello stampo e, una volta solidificato, il pezzo viene liberato distruggendo lo stampo in terra.

Questa tecnica di produzione, a differenza della fusione in conchiglie e pressofusione, viene usata per la realizzazione di pezzi unici o in piccola serie.

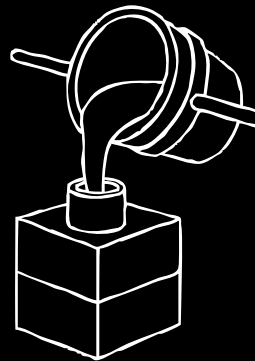

## Cast aluminum furniture

*To manufacture cast aluminum furniture, Elite To Be chooses what is probably the most traditional and ancient foundry manufacturing technique: sand casting. The process begins with a model, made of wood, aluminum, or resin, out of which a mold is made using a particular type of sand, called molding sand.*

*Cast metal is then poured into the mold and once solidified, is broken out of it.*

*Unlike shell mold casting, or high pressure die casting, this manufacturing technique is used to produce either one-off pieces or small run items. Unlike shell mold casting, or high pressure die casting, this manufacturing technique is used to produce either one-off pieces or small run items.*

### Pezzi unici

L'artigianalità del processo di colata in terra determina che ogni fusione di alluminio sia diversa dalle altre, mai uguale a se stessa.

I pezzi originati presentano quindi piccole imperfezioni e impurità che sono uniche, non ripetibili: questo è il carattere distintivo e originale di ogni complemento Elite To Be.

### Finiture di pregio

Un volta realizzata la fusione del pezzo questo viene rifinito o rimuovendo le sbavature e trattando la superficie con finitura a lucida o spazzolata.

Sono disponibili anche metalliche con cromie ottone, piombo, nickel e bronzo diamantato.

### Unique craft aluminum pieces

*The craftsmanship beyond the sand-casting process makes the outcome of each cast different from the others. The small imperfections and impurities deriving from this technique of production make every piece of furniture unique and one-of-a-kind: this is the authentic and distinguishing character of each designer cast aluminum item made by Elite To Be.*

### Cast aluminum finishes

*Once the casting is done, the fettlings are removed, and the surface is either polished or brushed. Cast aluminum items can also be refinished in metallic colors such as brass, lead, nickel and diamond bronze.*

# TAVOLINI E SGABELLI COFFEE TABLES & STOOLS



## \_Otto Tall & Otto Low

Tavolini da caffè singoli, oppure pratici sgabelli,  
in fusione di alluminio, lucido.

*Coffee tables, or practical stools, in polished cast  
aluminium.*

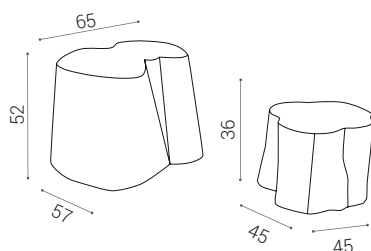

\_Finiture

\_Finishes



Otto Tall & Otto Low sono tavolini in  
fusione di alluminio che possono  
fungere anche da comodi sgabelli.

Singolare il contrasto tra  
le linee curve e la solidità materica  
dell'alluminio che può essere ri-  
nito con la lucidatura o spazzolatura.

Sono disponibili anche con  
verniciature diamantate o a polveri.

*Otto Tall & Otto Low are coffee tables,  
or practical stools,  
in polished cast aluminium.*

*Characterized by the contrast between  
the curved design and the solidity of  
aluminum, this model is manufactured  
in two finishes: frosted or polished.*

*Otto line of modern living room coffee  
tables are also available in diamond  
and powder paint.*



## Otto

Tavolo da caffè scomponibile in due tavoli singoli,  
in fusione di alluminio

*Coffee table that can be divided into  
two single tables, in cast aluminium*

\_Finiture *Finishes*

(A) (C) (P)

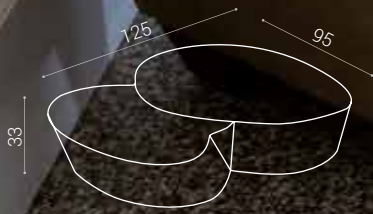



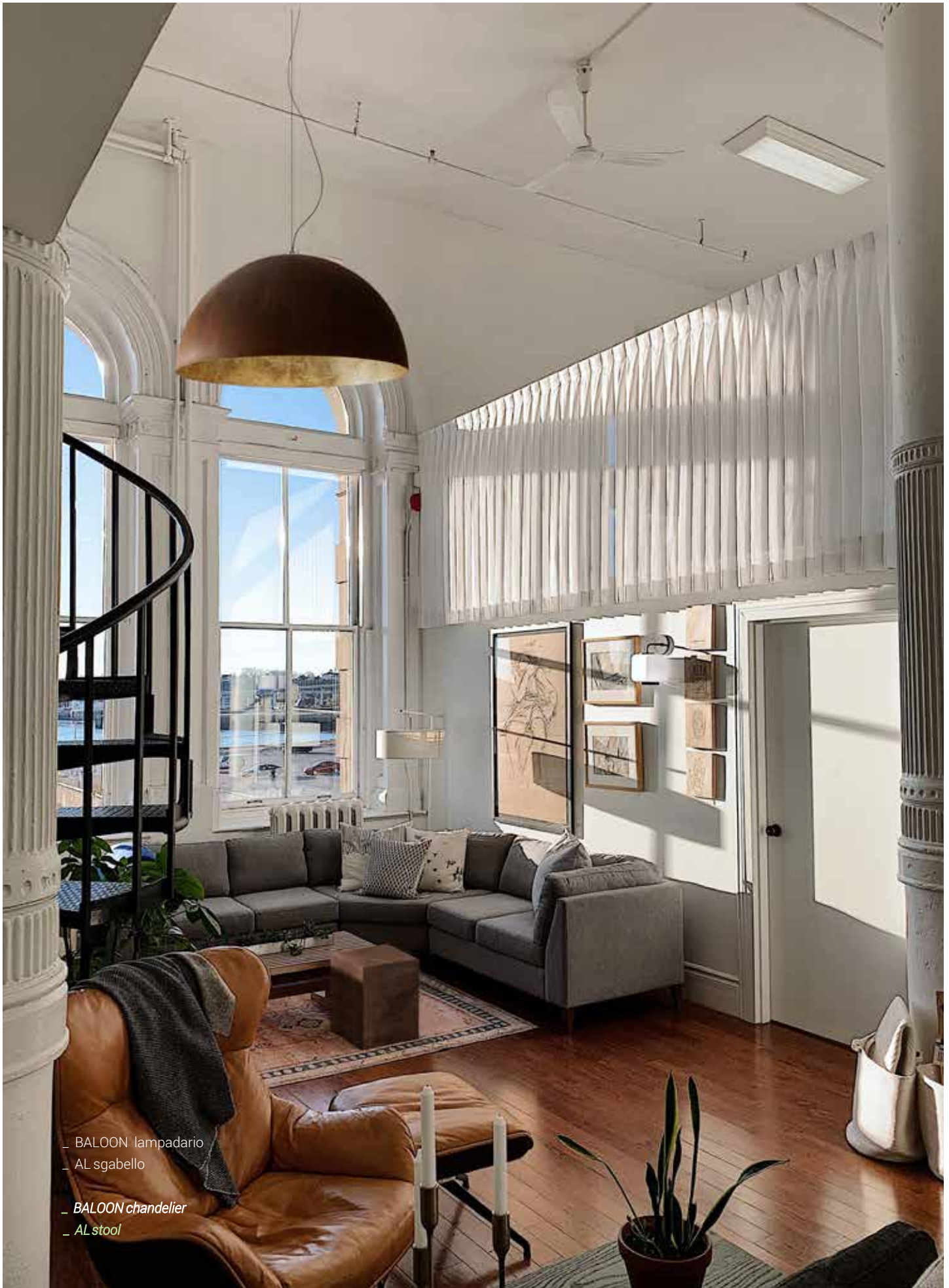

- BALOON lampadario
- AL sgabello
- BALOON chandelier
- AL stool

TAVOLINI E SGABELLI  
COFFEE TABLES & STOOLS



Esempio di finitura  
metallo smerigliato  
*Example of frosted  
metal finish*

La gradevolezza estetica degli **AL** deriva dall'incontro tra gli spigoli di una lamiera tagliata al laser, in cui le simmetrie specchiate della verniciatura metallica, diamantata o acidata o a polveri prendono vita rendendoli elementi sorprendentemente leggeri.

*The simple cube-shape design of the **AL** stool is obtained by joining the edges of laser cut sheet metal pieces; symmetries come to life in the mirror finish of the powder, diamond or etched metal coating and make this furniture element look as light as a feather.*



\_Finiture  
\_Finishes  
Ⓐ Ⓑ ⒫

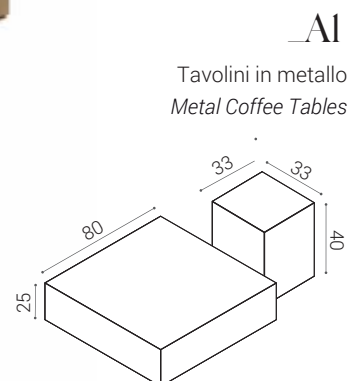

TAVOLINI E SGABELLI  
COFFEE TABLES & STOOLS

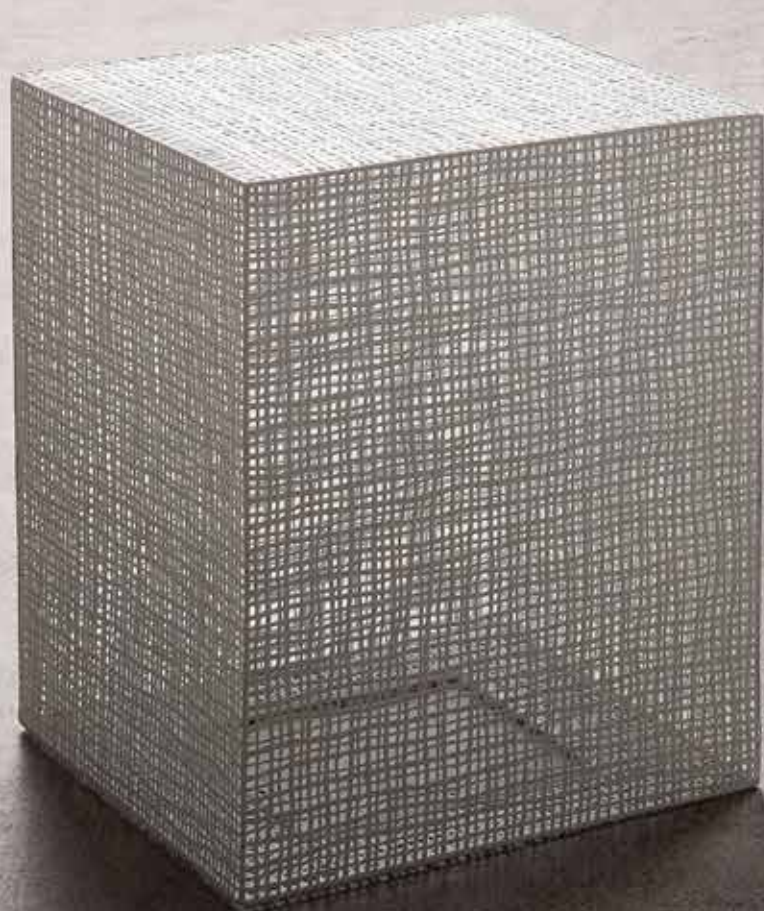



## Fil De Fer

I tavolini in metallo non sono mai apparsi così leggeri.

Una trama impalpabile di sottili fili di ferro pressati, intrecciati e verniciati, creano un gioco di pieni e vuoti dove le trasparenze caratterizzano in modo unico e originale i tavolini Fil de Fer di EliteTo Be.

### Fil De Fer

*Metal coffee tables never looked so light.*

*The thin texture of pressed iron wires, varnished and weaved together, creates a playful relationship between empty and full form in which the see-through effect gives a unique and original character to these low coffee tables for living rooms.*

TAVOLINI E SGABELLI  
COFFEE TABLES & STOOLS

Fil De Fer

Tavolini in filo di ferro  
*Iron wire coffee tables*

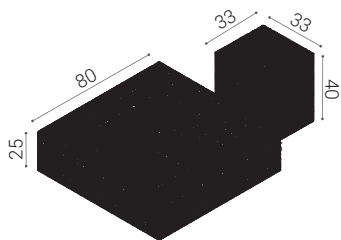

Finiture  
Finishes

 Grigio Antracite  
*Anthracite Grey*

 Bianco  
*White*



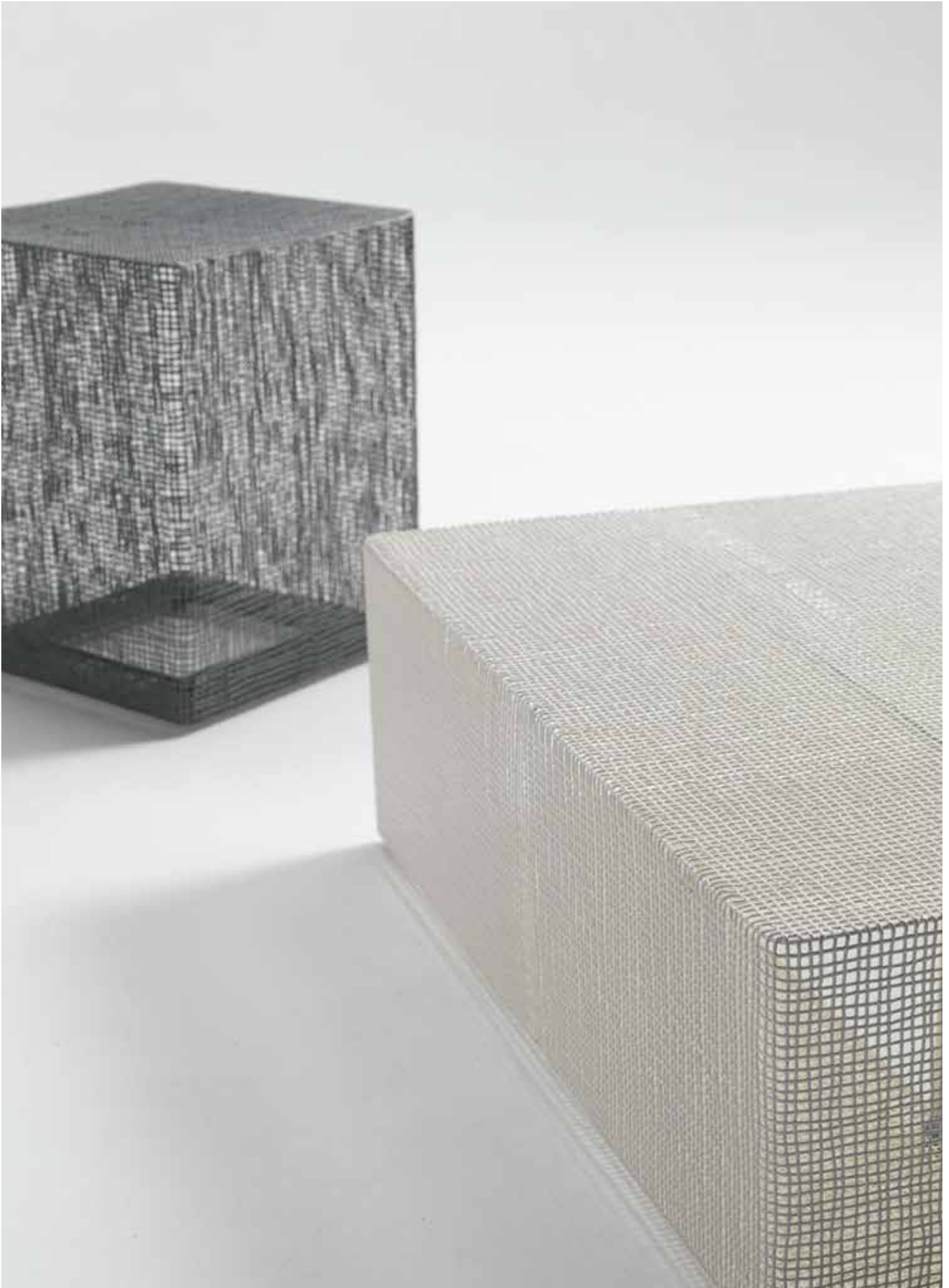

# TAVOLINI E SGABELLI COFFEE TABLES & STOOLS

Disegnato a sezione conica, lo sgabello KETIL è realizzato in metallo tagliato a laser, è disponibile nelle finiture metalliche diamantate, acidate o polveri.

Questo sgabello di design trova la sua naturale collocazione in abbinamento alla libreria DODA di Elite To Be.

*KETIL is a laser-cut metal stool with a conic section design; it is available in powder, diamond and etched metal finish.*

*This designer stool finds its natural match with Elite To Be's DODA library.*



## \_Ketil

Sgabello a sezione conica in metallo  
*Stool with conical section in metal*

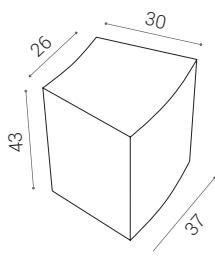

\_Finiture  
\_Finishes







TAVOLINI E SGABELLI  
COFFEE TABLES & STOOLS



TRIS è un set di tre tavolini in metallo impilabili lateralmente con piano rotondo e una base formata da tre gambe sottili la cui silhouette crea un gioco raffinato di vuoti e di incastri.

Acquistabili anche singolarmente nelle tre misure del piano  $\varnothing 36$ ,  $\varnothing 47$  o  $\varnothing 60$  e grazie alle numerose varianti di finitura: corten, brunito o bronzato manuale nickel, bronzo, ottone e piombo diamantato o a polveri in 9 colori, si presta ad essere utilizzato in spazi pubblici o privati.

*TRIS is a set of three stackable round side tables.*

*The base of these coffee tables consists of three thin legs whose silhouette creates a refined overlapping visual effect.*

*Items can be purchased separately in the three different sizes ( $\varnothing 36$ ,  $\varnothing 47$  and  $\varnothing 60$ ) and are available in several finishes: etched corten, burnished, bronze, or Diamond nickel, bronze, brass and lead, or powder finish in 9 colors. These metal coffee tables can be used both for domestic and public interiors.*

\_Tris

Tavolini in metallo inseribili lateralmente  
Stackable metal table

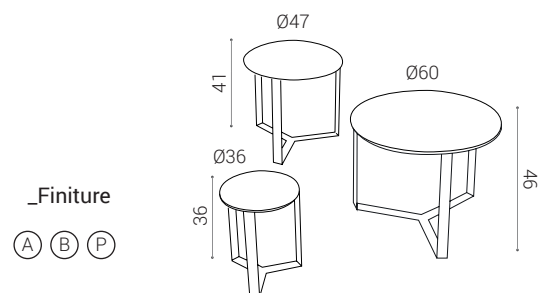





## \_Hug

Sgabello in abete massello con maniglia in corda intrecciata.

*Stool in solid fir with woven rope handle.*

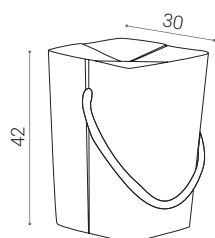

### \_Finiture

#### \_Finishes

##### Legno

	Abete Naturale <i>Fir natural finish</i>
	Abete Grigio <i>Fir Grey finish</i>

##### Corda

#### Rope

	Bianco <i>White</i>		Verde <i>Green</i>
	Nero <i>Black</i>		Blu <i>Blue</i>
	Rosso <i>Red</i>		Canapa <i>Hemp</i>

Singolare nella forma, lo sgabello **Hug** è composto da quattro parti in abete massello con finitura naturale o grigia, è corredato da una maniglia in corda intrecciata disponibile in diverse colorazioni.

***Hug** stool is made up of four parts in solid fir with a natural or gray finish, in a singular conic shape. It is equipped with a woven rope handle, made in cotton of different colours.*



TAVOLINI E SGABELLI  
COFFEE TABLES & STOOLS

- \_ MOOIE libreria
- \_ KROSS tavolino
- \_ HUG sgabelli

- \_ MOOIE bookcase
- \_ KROSS coffee table
- \_ HUG stools

\_Kross

Tavolino basso da salotto in legno di Suar.

KROSS è un tavolino basso da salotto caratterizzato da un design minimale e lineare.

Il piano del tavolo in legno massello di Suar, con finitura a cera, è sostenuto da una base in metallo in un affascinante mix di materiali.

I contrasti cromatici delle diverse parti sono evidenziati dalle ampie sezioni in legno e trasmettono un senso di energia, forza ed eleganza naturale.

\_Kross

A Suar wood low coffee table for living rooms characterized by a smooth minimal design.

The Suar solid wood table top, in wax finish, is supported by a metal base in a fascinating mix of materials.

The contrasting colors of the different parts are highlighted by the large wood sections and convey a sense of energy, strength and natural elegance.



\_Kross

Piano in suar massello e base in metallo  
Suar wood top with metal legs

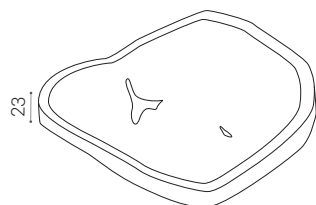

Ø80/90 - Ø100/120

\_Finiture  
\_Finishes



Suar  
Suar





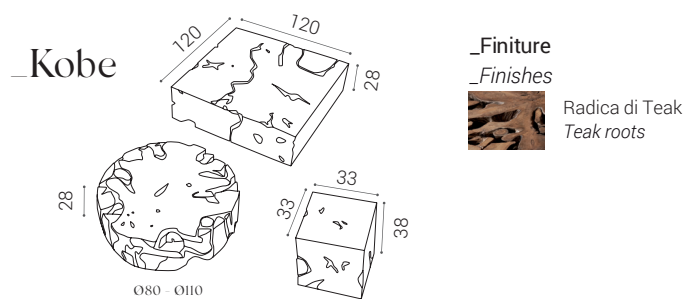

Realizzati interamente a mano, questi tavolini in radice di Teak esaltano la intrinseca creatività della natura. La radice di legno, levigata e lucidata, crea forme geometriche uniche che contrastano con l'irregolarità della grana interna. Ogni tavolino è un oggetto unico nel suo genere e può essere integrato in qualsiasi stile di arredamento. **Kobe** è disponibile nella versione circolare Round o quadrata Square.

*Completely handcrafted, these Teak coffee tables bring out Nature's intrinsic creativity. The wood root, smoothed and polished, creates unique geometric shapes in contrast with the irregular wood grain. Every Teak root table is a one-of-a-kind piece the fits any style of indoor furniture.*

**Kobe** is available in two versions: Round (round-shaped) and Square (square-shaped).

## La radice di Teak

La radice di tek proviene da un albero tagliato decine di anni prima, che, grazie alla idrorepellenza del legno, non si è decomposto nel terreno.

La radice viene estratta dal terreno manualmente con l'ausilio di buoi per strapparla dal terreno, viene pulita, levigata, tagliata e sagomata.

Grazie all'idrorepellenza la radice di Teak può essere esposta direttamente anche all'esterno dove tenderà ad assumere un colore argentato. Per sua natura ogni pezzo è unico, per questo un tavolino in radice non passa mai inosservato e dona prestigio alla vostra abitazione.

## Teak roots

*Teak roots come from trees there were cut down decades ago; since Teak wood is naturally water-repellent, these roots don't decay when left in the soil.*

*The roots are manually extracted from the ground, cleaned, smoothed, cut and shaped.*

*Being naturally water-proof, teak roots are also suitable for outdoor use, where they tend to develop a silver shade of color.*

*Since each piece is naturally unique, Teak roots tables never go unnoticed and add prestige to every house.*



- \_ KOBE tavolino
- \_ NEST lampadario
- \_ KOBE coffee table
- \_ NEST chandelier

TAVOLINI E SGABELLI  
COFFEE TABLES & STOOLS



TAVOLINI E SGABELLI  
COFFEE TABLES & STOOLS



**\_Igloo**

Sgabello in fusione di alluminio  
*Cast aluminum stool*

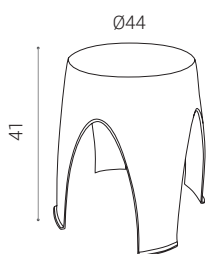

**\_Finiture**



Alluminio  
lucido



Alluminio  
spazzolato



**\_Finishes**

*Aluminum  
Glossy*

*Aluminum  
Frosted*

Come l'acqua scorre e si trasforma in ghiaccio, la fusione di alluminio si lascia modellare e diventa IGLOO.

Ricordando la forma caratteristica dei rifugi degli Inuit, questo sgabello in metallo ha un'eleganza naturale, primitiva.

Disponibile in alluminio lucido, spazzolato, o nelle finiture metalliche diamantate o a polveri, la forza iconica di questo sgabello completa uno spazio living o pubblico con personalità.

*As the water flows and turn into ice, so aluminum melts and is cast into IGLOO.*

*With a design that reminds of Inuit shelters, this metal stool has a natural and primitive elegance.*

*Available in polished or brushed aluminum, and in satin or diamond metal finish, this stool is full of character and adds value both to home living areas as well as to public environments.*





# Madie e credenze

Convivium e Stratos sono le tipologie di madia proposte da Elite To Be.

Convivium è un complemento pensato per gli amanti del buon vino che vogliono tenere in casa un vero e proprio wine-bar completamente attrezzato.

Stratos è una moderna madia che, attraverso il sapiente utilizzo del mosaico, offre molteplici soluzioni per arredare in modo unico e originale ambienti prestigiosi e di stile.



## SIDEBOARDS

*Stratos and Convivium are functional cupboards with exclusive features.*

*Convivium is the missing "cellar" ... designed for lovers of good wine who want to keep at home a real wine-bar, fully equipped.*

*Stratos cabinet consists of a rectangular structure with a minimalist design base and four panel doors finished in the style of the traditional mosaic technique from Friuli.*





## Il mosaico

Il mosaico è una tecnica policroma che ha avuto origine in oriente oltre 5000 anni fa, esportata poi nel mondo dell'antichità durante il periodo ellenistico e romano, ha trovato nuovo splendore nella Venezia del XVI secolo.

Protagonisti di questa rinascita sono i "terrassier" friulani provenienti dalle zone di Sequals e Spilimbergo, ambito dove oggi opera la prestigiosa Scuola Mosaicisti del Friuli fondata nel 1922.

Da questo patrimonio storico di conoscenze artistiche ed artigianali trovano origine le finiture della nostra madia Stratos, un complemento dall'alto valore estetico capace di dare nuova luce ai vostri ambienti.

## Mosaic

*Mosaic is an ancient polychrome technique that originated in the East more than 5000 years ago and later spread to the rest of the world during the Hellenistic and Roman age; it flourished again in 16th-century Venice.*

*Central to this revival were the craftsmen (known as "terrassier") coming from the area between two towns, Sequals and Spilimbergo, of the Italian region of Friuli Venezia-Giulia; here the "Scuola Mosaicisti del Friuli", a prestigious mosaic school founded in 1922, is still active today.*

*This wealth of artistic and artisanal knowledge is not only part of our historic heritage, but also at the heart of our Stratos model. Decorated with mosaics, this valuable furniture item can make a difference in every setting.*

### Il valore della pazienza

La bellezza dei mosaici Stratos prende vita da un ingrediente molto raro nella vita contemporanea, la pazienza.

Una virtù necessaria per unire con calma e precisione le migliaia di tessere che vanno a comporre un mosaico di qualità, senza il ricorso alle macchine ma alla sola esperienza e abilità manuale dei maestri artigiani.

### *The value of patience...*

*The beauty of Stratos mosaics becomes real thanks to a very rare ingredient in contemporary life, "patience".*

*A virtue necessary to combine the thousands of tiles calmly and precisely to compose a quality mosaic, without resorting to machines but only to the experience and manual skill of master craftsmen.*



Mosacio Terracotta  
Brick mosaic

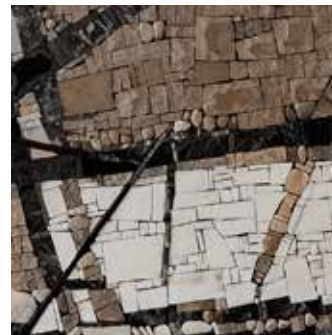

Exclusive  
Exclusive

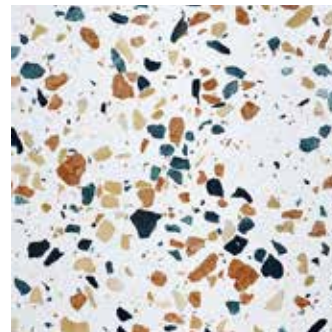

Terrazzo Veneziano  
Venetian terrace

## \_Stratos

Semplicità nelle forme e preziosità nei rivestimenti, queste le peculiarità della madia di design STRATOS.

Presenta una struttura rettangolare con una base minimale in metallo, interno impiallacciato noce e ripiani in vetro extrachiario.

Le quattro ante frontali sono disponibili nelle varianti mosaico Exclusive, Terracotta e Terrazzo Veneziano o in argilla biocompatibile.

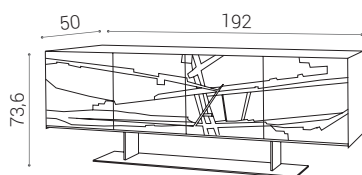

### \_Finiture

#### \_Finishes

Struttura  
Metal Structure



#### Ante

Mosaico  
Exclusive



Terrazzo  
Veneziano



Mosaico  
Terracotta



Argilla



#### Doors

Exclusive  
Mosaic

Venetian  
Terrace

Brick  
Mosaic

Clay

## \_Stratos

*Simple shape and precious coverings: these are the distinctive features of STRATOS, our designer cupboard.*

*This model consists of a rectangular structure, with a metal skin and a minimalist design base, the inner body is made in walnut veneer with clear glass shelves.*

*The four panel doors are available in the Exclusive, Terracotta, Terrazzo Veneziano mosaic finishes or in bio-compatible clay.*



### il mosaico terracotta

Materico, caldo, raffi nato e sensuale...sono solo alcuni degli aggettivi che raccontano il mosaico terra di Stratos, Una soluzione estetica esclusiva, mai uguale a se stessa, dove l'artigianalità della lavorazione consente a Stratos di diventare un complemento unico e originale per arredare in modo esclusivo i vostri ambienti.

### the brick mosaic

*Material, warm, refined and sensual...these are just some of the adjectives that describe the land mosaic of Stratos, An exclusive aesthetic solution, never the same, where the craftsmanship of the workmanship allows Stratos to become a unique and original complement to furnish your environments in an exclusive way.*





## il mosaico exclusive Exclusive Mosaic

Il mosaico è una tecnica policroma, ottenuta mediante l'utilizzo di frammenti di materiali, nata in Mesopotamia ed esportata nel mondo dell'antichità durante il periodo della dominazione ellenistica e romana.

Le tessere di diversa natura e colore (pietre, vetro, conchiglie), sono decorate con oro e pietre preziose. Le tonalità neutre del grigio, del nero e dell'avorio unite agli inserti in Carrara bianco donano una luce tutta particolare al mosaico Exclusive, un'aurea preziosa che si abbina perfettamente in ambienti prestigiosi e di un lusso elegante.

*The mosaic is a polychrome technique, obtained through the use of fragments of materials, born in Mesopotamia and exported to the world of antiquity during the period of Hellenistic and Roman domination.*

*The neutral shades of grey, black and ivory, together with the white inserts of Carrara marble, give the Exclusive mosaic an extremely peculiar light.*

*A precious aura that makes of this cupboard an ideal furnishing item for prestigious and luxury environments.*





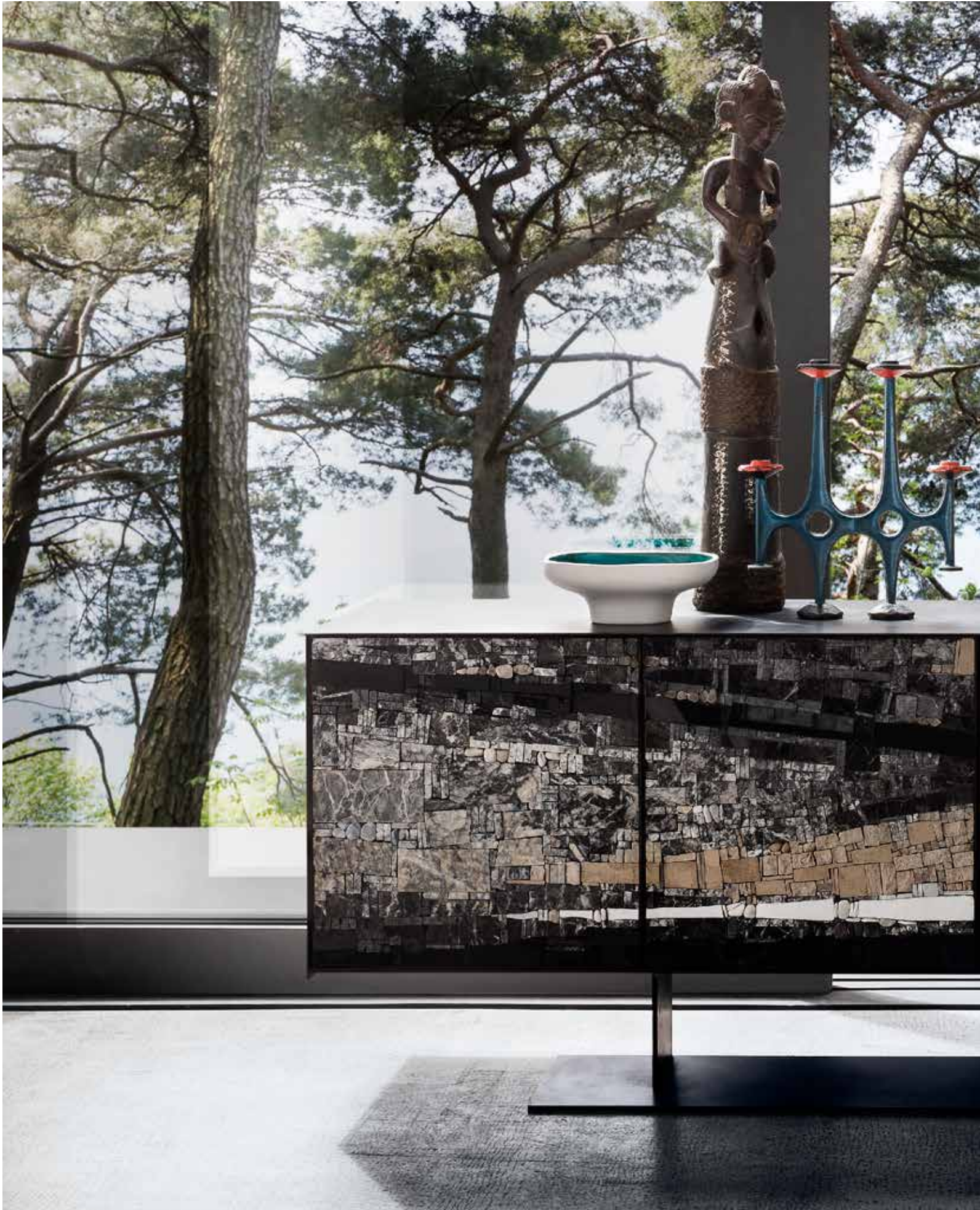



MADIE E CREDENZE  
SIDEBOARDS



## il terrazzo veneziano

Il terrazzo alla veneziana, detto anche «seminato alla veneziana» è una pavimentazione così chiamata perché, per quanto sia di antica origine greca, è nella città lagunare che ha raggiunto il massimo sviluppo e splendore.

È composta da granulati di marmo tenuto assieme da un legante a base di calce.

È un'opera unica con le sue cromie, i suoi pezzi colorati; sempre diverso nella realizzazione è impossibile riprodurre la stessa tessitura o la stessa semina.

Ancora oggi, esattamente come veniva lavorato cinquecento anni fa nelle nobili dimore veneziane, il terrazzo veneziano viene applicato su Stratos generando un complemento adatto a qualsiasi tipo di ambiente, classico o contemporaneo.

## venetian terrace

*The Venetian-style flooring floor is a flooring technique that, although invented in ancient Greece, was later developed to its full potential in Venice.*

*This flooring is made of marble granules bonded by a lime-based binding agent.*

*This contemporary design sideboard, with the colors and shades of its marbles, is a unique work of art: each piece is different from the others since it is not possible to reproduce the same texture twice.*

*Today the Terrazzo Veneziano finish is applied on our Stratos model with the very same technique that was used 500 hundred years ago in the noble palaces of Venice; the result is a furniture item that fits in both classic and contemporary settings.*



- \_ STRATOS madia
- \_ TERNO specchiere
  
- \_ STRATOS sideboards
- \_ TERNO mirrors



MADIE E CREDENZE  
SIDEBOARDS

*Argilla bio-compatibile*

Stratos è disponibile anche  
nella versione con ante  
rivetsite in argilla  
bio-compatibile

*Clay bio-compatibile*

*Stratos is also available  
with doors panels in clay  
bio-compatible finish.*

# Convivium

Per gli amanti del buon vino e della convivialità, Elite To Be ha creato Convivium.

Una elegante madia appositamente studiata per ospitare le tue bottiglie di pregio e tutto l'occorrente per una corretta degustazione. Convivium, disponibile nelle versioni Slim e Bold, è ideale per gli ambienti domestici ma anche in strutture ricettive per offrire un servizio esclusivo agli ospiti.

## il wine bar strutturato

La luce interna sulle porte e sul top, i cassetti con vassoi, le ante interne attrezzabili con portabottiglie e portabicchieri sono gli elementi che rendono la madia Convivium un vero e proprio wine bar domestico completamente attrezzato per una perfetta degustazione del vino in compagnia.

## il wine dispenser per un'ottima degustazione

Gli interni di Convivium sono predisposti per ospitare anche un pratico e utilissimo wine dispenser per conservare alla giusta temperatura e nelle condizioni ideali le tue bottiglie d'annata.

# Convivium

*Elite To Be's Convivium was conceived with those who love fine wine and conviviality in mind.*

*This elegant cupboard is designed to store your premium bottles together with everything you need for the perfect pour. Available in the Slim and Bold versions, Convivium is a modern cupboard which suits both home wine passionate, and for professional use to provide exclusive service to hotel guests.*

## A fully-equipped wine bar

*The door and top with built-in lights, the drawers with trays and the inner side of the doors that can be fitted with glass holders and wine racks, turn the Convivium cupboard into a real home bar, fully equipped for perfect wine tasting among friends.*

## The wine dispenser for ideal tasting

*Convivium is designed to accommodate a built-in wine dispenser, a functional and useful solution to preserve your vintage wines at the right temperature under the most ideal conditions.*





LE DUE TERRE  
VINO COLD ORIENTALI  
MERLOT  
2012



01 Anta attrezzata con ripiani regolabili multiuso, illuminata con led a sensori di prossimità e crepuscolare

02 Mensola in vetro con frontale in legno

03 Portabicchieri estraibile

04 Wine dispenser

05 Vassoio estraibile

06 Cassetto multiuso

07 Top con luce LED

08 Anta illuminata con portabottiglie Win-O

09 Vano porta liquori e bicchieri

*01 Door equipped with shelves adjustable multipurpose, illuminated with LED sensors proximity and twilight*

*02 Glass shelf with wooden front*

*03 Removable glass holder*

*04 Wine dispenser*

*05 Removable tray*

*06 Multipurpose drawer*

*07 Top with LED light*

*08 Illuminated door with*

*Win-O bottle holder*

*09 Compartment for spirits and glasses*



\_Finiture  
\_Finishes

**Interno**

Argilla grigio



**Interior**

Grey Clay

**Esterno**

Rovere Silver



**Exterior wood**

Silver Oak

Rovere



Oak Natural

Noce Canaletto



Canaletto Walnut

Esterno telaio  
Metal structure

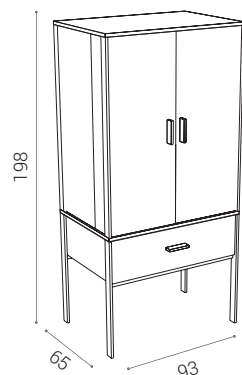

\_Convivium Slim

Slim: il Convivium nella sua forma più slanciata. Le sue linee essenziali e contemporanee, esaltate dall'eleganza del legno e dalle pregiate finiture delle parti metalliche, fanno di questa madia un complemento ideale per ambienti moderni e strutture alberghiere dal design minimale.

\_Convivium Slim

*Slim: a sleek shape version of Convivium. Its contemporary and essential design, enhanced by the elegance of wood and by the refined finishes of its metal parts, makes of this metal and wood cupboard a furniture item that perfectly fits both modern style domestic interiors and minimalist hotels.*





MADIE E CREDENZE  
SIDEBOARDS







<b>_Finiture</b> <b>_Finishes</b>	Parti in metallo Metal parts	
Interno e Esterno Interior and Exterior	(A)	(P)
Rovere Silver		Silver Oak
Rovere		Oak
Noce Canaletto		Canaletto Walnut

### *\_Convivium Bold*

*Bold: a massive version of Convivium. With its grand and monumental design, this cupboard was conceived to provide luxury interiors with an eye-catching piece of furniture that definitely will not go unnoticed.*

*Convivium Bold is also equipped with a functional refrigerated wine cellar to properly store your wines.*

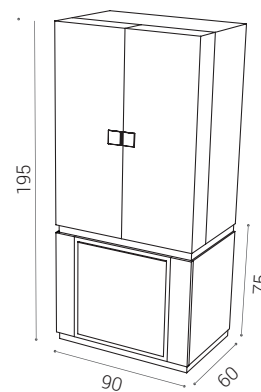

### *\_Convivium Bold*

Bold: la versione massiccia di **Convivium**.

Suntuosa e monumentale, questa madia è stata progettata per arredare spazi di lusso importanti, con un effetto scenico prestigioso che non passa sicuramente inosservato.

**Convivium Bold** è anche equipaggiata con una comoda cantinetta refrigerata per la corretta conservazione del vino.

# Illuminazione

L'ampia varietà di forme, dimensioni, stili e materiali di realizzazione contribuiscono a rendere importante e unica la proposta Elite To Be per illuminare i vostri spazi, con complementi dal design singolare e ricercato.



## *Lighting*

*Metal chandeliers or ceramic table lamps, pendant lights or wall lightings: Elite To Be's range of product always provide you with unique lighting solutions to illuminate in an original and refined way either your home or your business premises. Our lamps are all handcrafted, manufactured with care to details to add value to your lighting fixtures.*







ILLUMINAZIONE  
LIGHTING



Questo lampadario in metallo a sospensione diffonde una luce soffusa creando un'atmosfera accogliente.

Baloon è disponibile in cinque diverse dimensioni e numerose finiture e può quindi essere usata singolarmente per illuminare il tavolo di una sala da pranzo, o in gruppo sopra un bancone bar o di una cucina.

L'esterno è disponibile nelle finiture metalliche diamantate o nelle finiture manuali corten, brunito o bronzato, oppure a polveri - l'interno può essere rifinito bianco o foglia oro o argento

*This metal pendant chandelier sheds soft light and creates a cozy atmosphere.*

**Baloon** is available in five different sizes and finishes.

*This designer ceiling lamp can be used either singularly to light a dining room, or as a group of lamps hanging above a bar counter or a kitchen peninsula. External finishes range from satin or diamond coated metal ones to handcrafted corten, burnished and bronze ones, with a gold or white interior.*

## **Baloon**

Lampada in metallo  
Metal Chandelier

### **\_Finiture \_Finish**

Esterno  
Exterior



Interno  
Interior

Bianco  
White



Foglia Oro  
Gold Leaf



Foglia Argento  
Silver Leaf

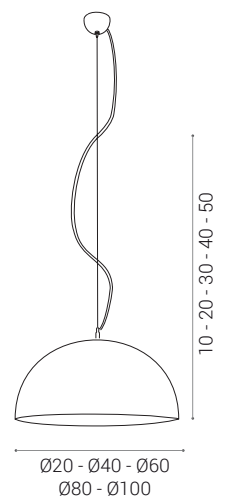



La lampada artigianale a sospensione LENTI è l'elemento a luce diffusa con più varianti di dimensione e finitura disponibili.

Con ben cinque diametri differenti e molteplici colorazioni esterne tra cui le finiture metalliche diamantate, le finiture manuali acidate e la verniciatura a polveri, rappresenta un classico del design moderno, industriale e scandinavo.

*LENTI is our handcrafted hanging light solution for flood illumination; this product has the widest range of size and finish options available.*

*With 5 different diameters and 14 different color finishes - including diamond metal finishes, the handcrafted etched finishes, powder coating, - this item is a classic of modern, classic and Scandinavian design.*

## Lenti

Lampade retrò in metallo  
*Vintage design metal lamp*

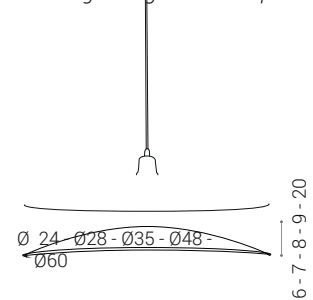

### Finiture Finishes

- Interno  
*Interior*
- Bianco  
*White*
- Esterno  
*Exterior*
- (A) (B) (P)





- \_ NEST lampadario
- \_ AL sagabelli
  
- \_ NEST chandelier
- \_ AL stools



NEST è una lampada a sospensione finemente realizzata in tubolare di ferro intrecciato a mano.

Disponibile in tre modelli, la lampada Nest, realizzata con straordinaria maestria artigiana, si ispira, come evocato dal nome, alla form naturale dei nidi degli uccelli.

*NEST is a suspension lamp finely made of hand-woven iron tubing.*

*Available in three models, the Nest lamp, made with extraordinary craftsmanship, is inspired, as evoked by the name, by the natural shape of birds' nests.*

## Nest midi

Lampada in tubolare di ferro intrecciato a mano  
*Hand woven tubular iron wire lamp*

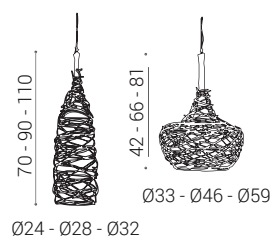

### \_Finiture \_Finishing

<b>Esterno</b> Bronzo antico		<b>Exterior</b> Antique Bronze
<b>Interno</b> Finitura dorata		<b>Interior</b> Golden

## Nest

Lampada in tubolare di ferro intrecciato a mano  
*Hand woven tubular iron wire lamp*

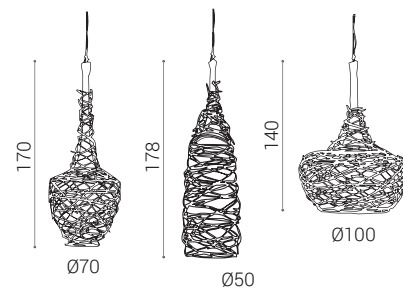

## Disegnare gli spazi con la luce

In Elite To Be siamo ben consci di quanta importanza rivesta la luce nel rendere le vostre dimore luoghi accoglienti e confortevoli.

Per questo prestiamo la massima attenzione nel darti complementi per l'illuminazione di design, capaci di arredare con gusto e portare la giusta luce nel tuo vivere quotidiano.

### *the light to design spaces*

*Metal chandeliers or ceramic table lamps, pendant lights or wall lightings: Elite To Be's wide range of product always provide you with unique lighting solutions to illuminate in an original and refined way either your home or your business premises.*

*Our lamps are all handcrafted, manufactured with care to details to add value to your lighting fixtures.*





## \_Gami

Lampada in ceramica con finitura  
esterna in cemento grezzo

*Ceramic lamp with rough concrete  
external finish*

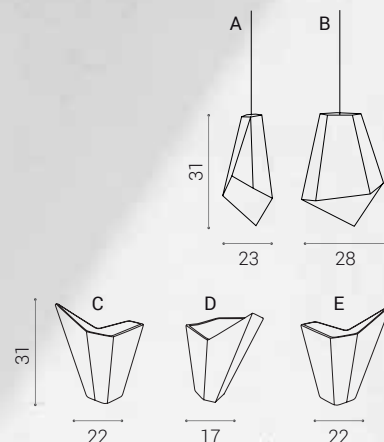

### \_Finiture

#### Esterno

Cemento

Interno

Bianco

Foglia  
oro

Foglia  
argento

### \_Finishes

#### Exterior

Cement

#### Interno

White

Gold  
Leaf

Silver  
Leaf

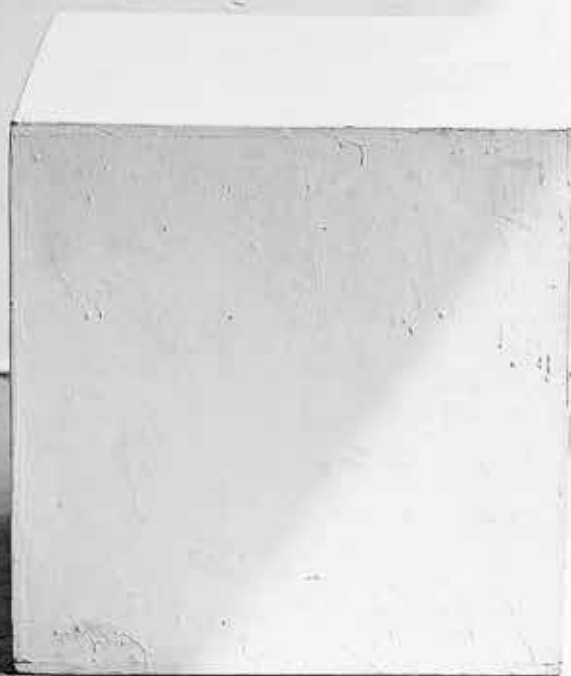

In grado di rievocare la sensazione di leggerezza degli origami, GAMI è una lampada in ceramica con rivestimento esterno in finitura cemento e interno bianco, foglia oro o argento.

GAMI è disponibile nella versione a sospensione o sottoforma di applique di design, è caratterizzata dalle spigolosità delle forme esaltate dall'artigianalità della finitura in cemento grezzo.

*Evocative of the lightness of origami, GAMI is a ceramic lamp with an external concrete finish and white, silver or gold leaf interior.*

*GAMI is available in two versions: hanging and wall lamp. This handcrafted ceramic lamp is characterized by the angular design and the by the craftsmanship of the rough concrete finish.*



ILLUMINAZIONE  
LIGHTING

- \_ TULI lampadario
- \_ AL sgabello
- \_ TULI chandelier
- \_ AL stools

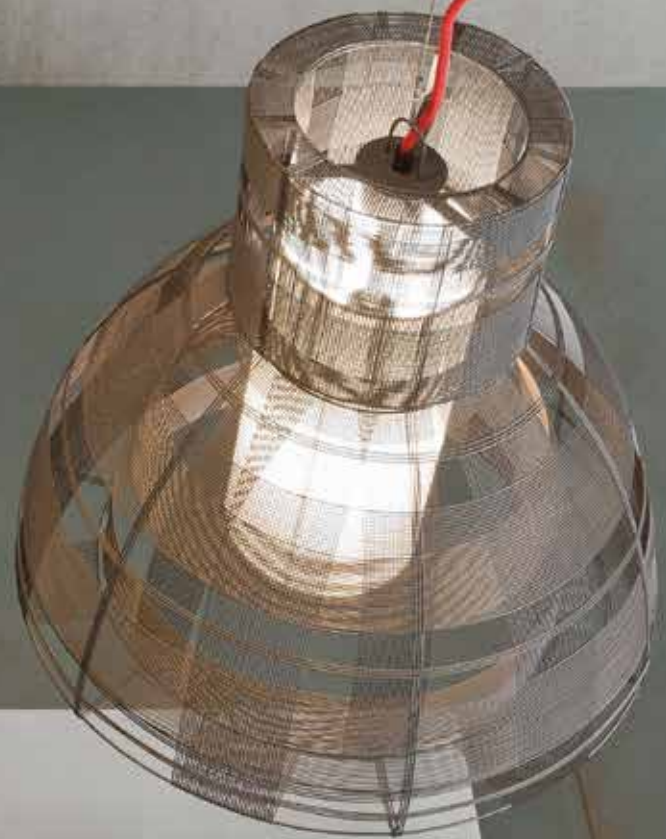
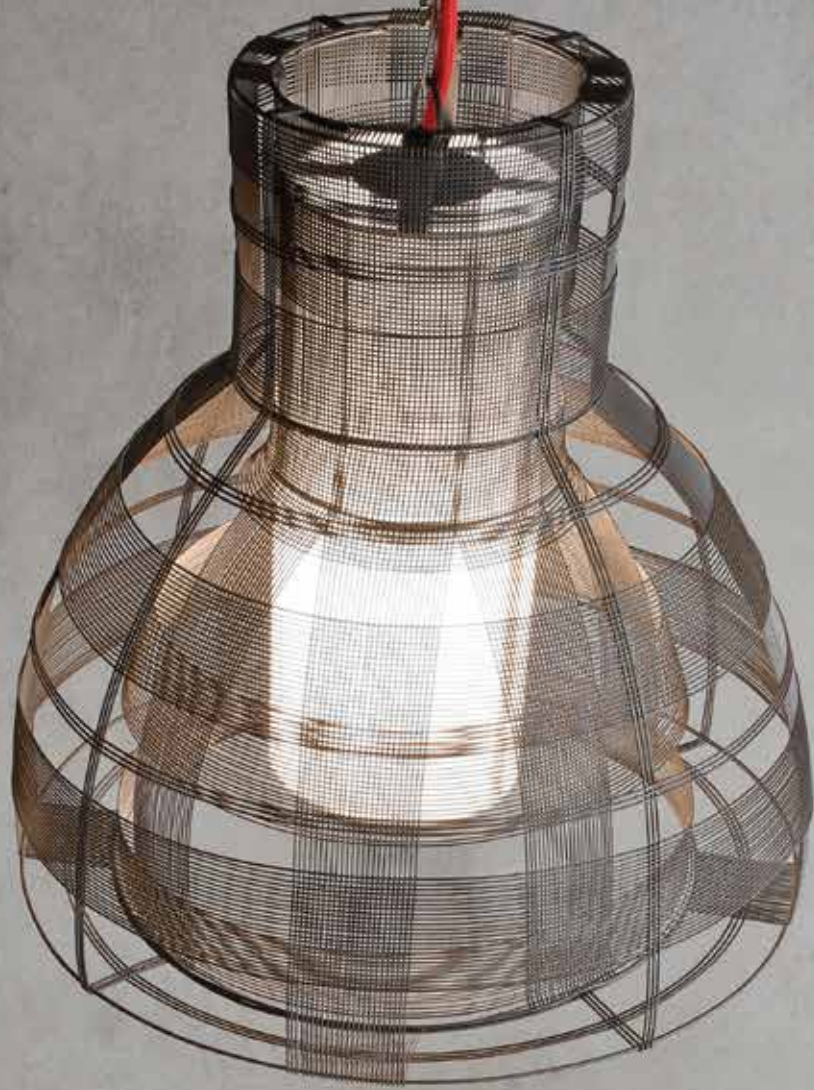

La lampada a sospensione TULI è caratterizzata da una trama irregolare ottenuta dall'intreccio di filo di ferro.

In questa lampada di design contemporaneo il metallo si traduce visivamente in estrema leggerezza con singolari effetti "moiré".

TULI è disponibile in tre dimensioni e due varianti di finitura: grigio antracite e bianco.

*TULI is a designer hanging light characterized by the irregular texture of the woven iron wire.*

*The use of metal in this contemporary design lamp yields a peculiar Moiré pattern which makes it seem almost weightless.*

*TULI is available in three different sizes and two finishes: white and dark grey.*



## \_Tuli

Lampada in filo di ferro intrecciato  
Woven iron wire metal lamp



### \_Finiture

Grigio  
Antracite

Bianco



### \_Finishes

Anthracite  
Grey

White



## Ekflamo

Lampada in lamiera  
piegata e saldata

*Folded and welded sheet  
metal lamp*

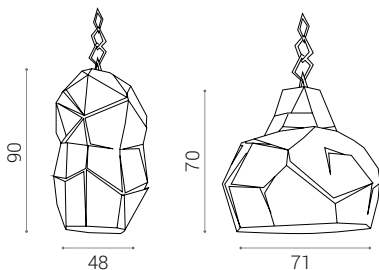

### \_Finiture \_Finishes



Bronzo antico  
Antique Bronze

Ⓑ

Ekflamo è una lampada in metallo a sospensione ricavata da una lamiera piegata e saldata, è caratterizzata dalla presenza di "tagli" che fanno filtrare singolari lame di luce. Ekflamo è disponibile esternamente nelle finiture metalliche diamantate nickel, bronzo, ottone o piombo o nella finitura acidata manuale bronzo antico.

*Ekflamo is a metal hanging lamp made by folding and welding sheet metal. The characteristic cuts on the lampshade allow the light to filter through.*

*Ekflamo is available in the following metal finishes: diamond coating, nickel, bronze, brass, lead and handmade burnished etched finish.*





## \_La Lun

Lampade in ceramica  
incisa a mano  
*Hand-engraved ceramic  
lamps*

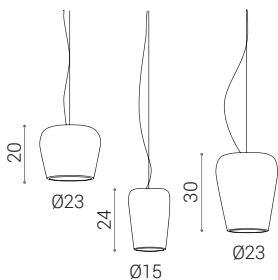

_Finiture	_Finishes	_Finiture	_Finishes
Esterno	<i>Exterior</i>	Interno	<i>Inner</i>
Bianco	White	White	White
Sabbia	Sand	Gold Leaf	Gold Leaf
Cacao	Cocoa		

LA LUN è una lampada in ceramica applicata in sospensione.

L'interno è disponibile bianco o foglia oro e l'esterno bianco, sabbia o cacao in tutte e tre le dimensioni esistenti.

L'esterno presenta un'interessante tecnica di incisione manuale, un graffio, in contrasto con la superficie liscia della ceramica di cui è composto.

*LA LUN is a hanging ceramic lamp.*

*LA LUN is a hanging ceramic lamp. Made in three sizes, its interior is available in two colors, white and gold leaf, while the exterior in white, sand or cocoa.*

*The exterior finish is made with a particular handcrafted technique in which scratches are engraved in contrast with the smooth ceramic surface.*



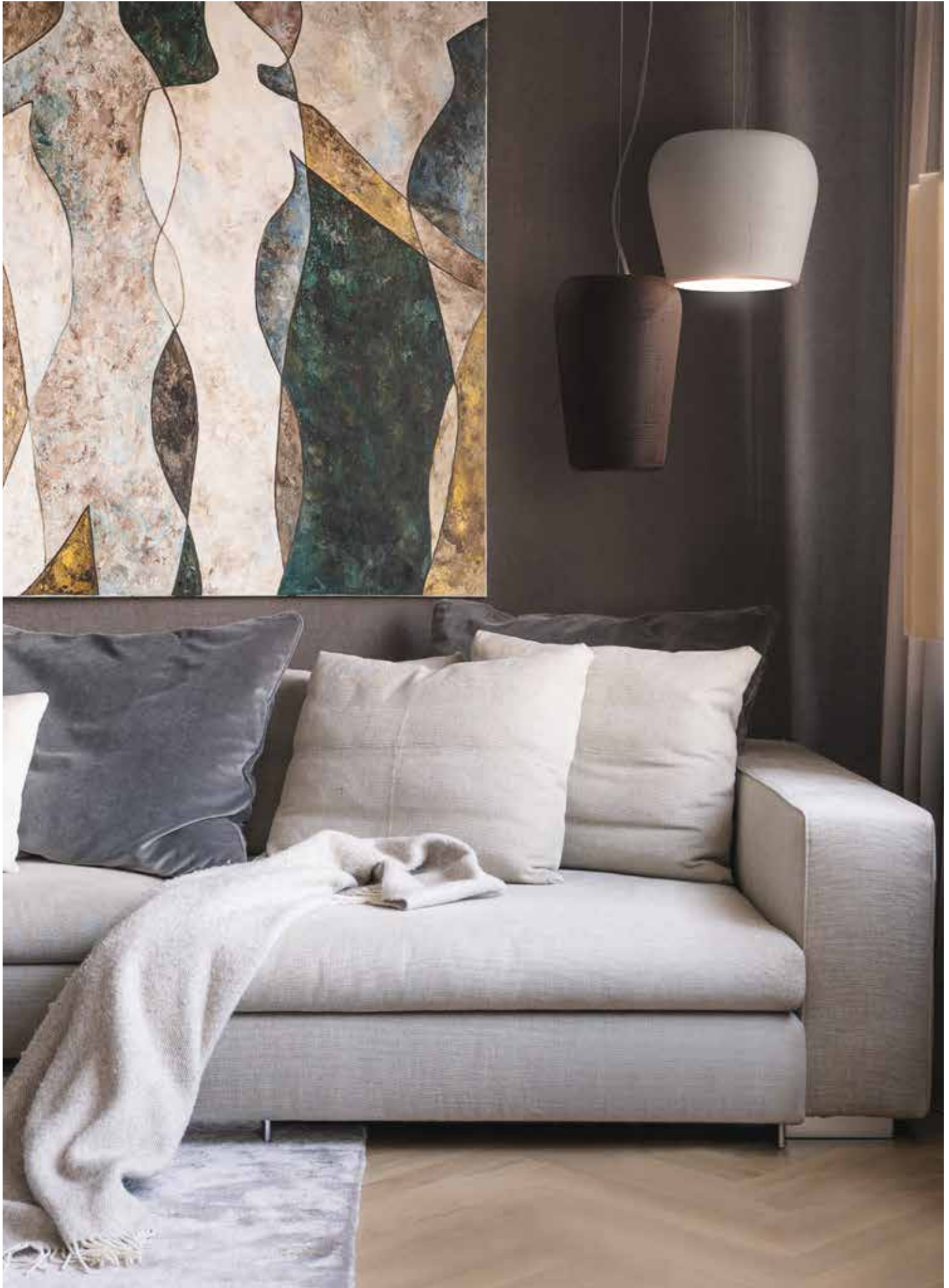



\_ ARBOJ lampada da terra  
\_ HUG sgabelli



\_ ARBOJ floor lamp  
\_ HUG stools

Con la lampada a terra ARBOJ la Natura si riprende il suo spazio.

La colonna in legno massiccio abbinata ad una base in metallo e il paralume in tessuto naturale sono le caratteristiche peculiari di questa lampada, disponibile in due altezze, che può essere, con creatività, inserita in ambiti classici o minimali.

*With the ARBOJ lamp, Nature retakes its place.*

*The solid wood body combined with the metal base and the natural fabric lampshade are the main characteristic of this model that, with a touch of creativity, can be used in classic as well as minimalist interiors.*



## \_Arboj

Lampade a to massiccio  
massiccio con paralume in tessuto  
*Solid wood floor lamp with fabric  
lampshade*

_Finiture		_Finiture
Piantana		Piantana
Rovere		Rovere
Suar		Suar
Base		Metal base
		(A) (B) (P)

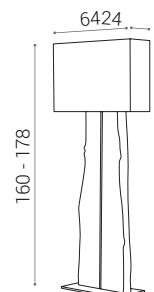



## \_Goblet

Lampada in metallo traforato  
*Perforated metal lamp*

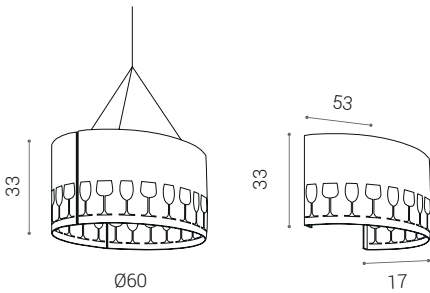

### \_Finiture \_Finishes

Esterno *exterior*



Interno *interior*



Specificamente progettata per arredare locali di degustazione, la lampada in metallo GOBLET è realizzata con lamiera traforata.

GOBLET è disponibile nella versione a sospensione e nella versione a muro.

*Specifically designed for wine tasting venues, GOBLET is a metal lamp made of perforated sheet metal.*

*GOBLET is available in two versions: hanging and wall lamp.*



# Librerie      *Bookcases*

Pensate per la loro funzione ma anche come elementi di arredo e di divisione degli spazi, le librerie Elite To Be rappresentano la giusta soluzione per chi vuole coniugare il piacere della lettura al quello del vivere in ambienti arredati con gusto. Le nostre librerie sono realizzate in legno e metallo ed abbiamo prestato particolare attenzione nel rendere disponibili una vasta serie di finiture perché tu possa disegnare la tua personale libreria moderna di design.

*The design aims, not only to fulfill the primary purpose of the bookcase, but to bring them to an unexpected role, becoming self-standing elements to divide the spaces in the room.*

*Elite To Be's bookcases are the perfect solution to combine the pleasure of reading with living in a house furnished with style.*

*Made of metal and wood, our bookcases are available in a wide array of finishes to allow you to design by yourself your own modern bookcase.*

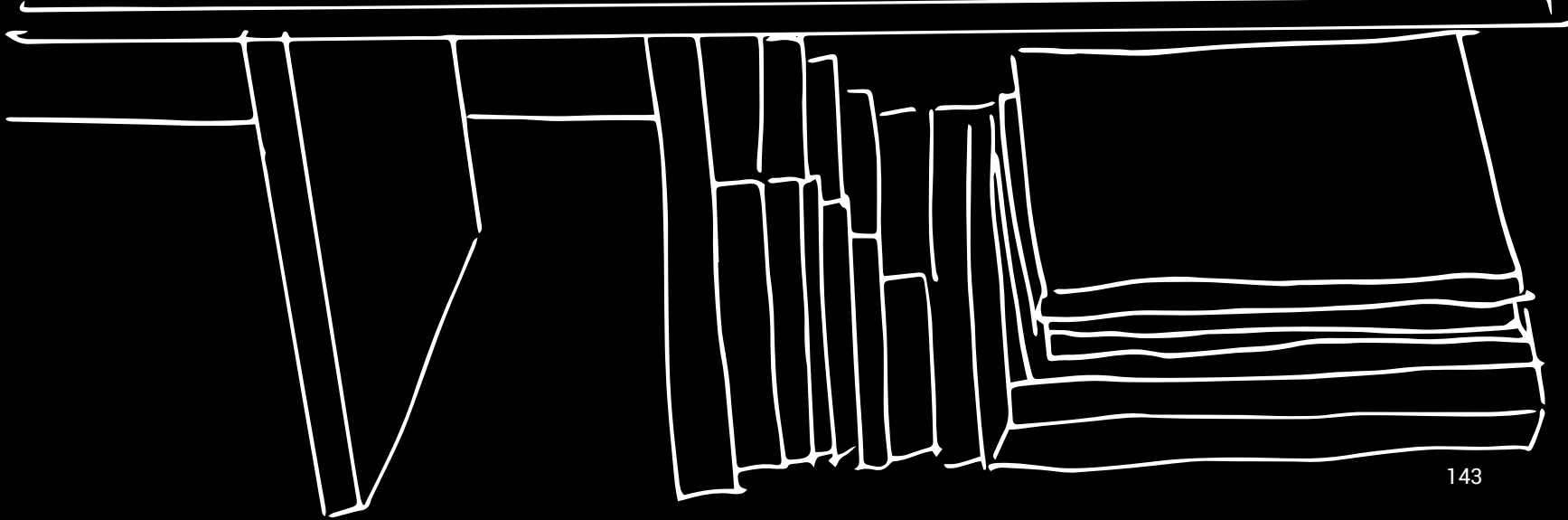
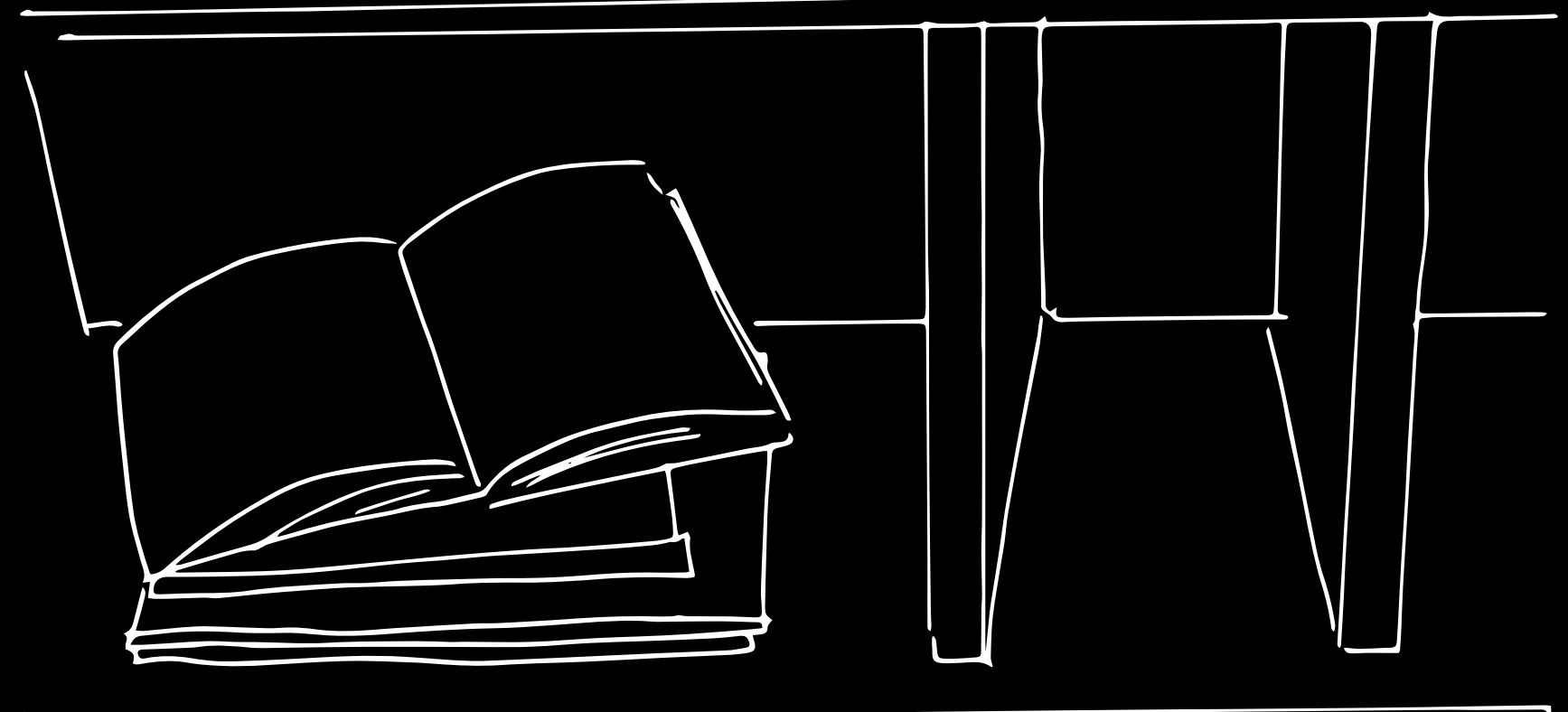

## — Hakkasan

Austera e versatile, la libreria bifacciale a giorno Hakkasan è caratterizzata da un'interazione dinamica tra volumi pieni e vuoti. Lamiere orizzontali supportano le partizioni in legno, che possono essere orientate creando numerose combinazioni. Grazie alla bifaccialità, questa libreria può fungere da elemento divisorio all'interno del zona soggiorno. I ripiani in metallo sono in finitura nickel, mentre base, top e tramezzi sono disponibili nelle finiture metalliche diamantate o a polveri.

## — Hakkasan

*Austere and versatile, the design of this two-faced bookcase is characterized by the relationship between empty and full components.*

*The vertical wood shelf-dividing panels, supported by horizontal metal sheets, can be arranged to create virtually any possible combination.*

*Being two-faced, KAKKASAN it is perfect as a living room divider.*

*Metal parts are available in diamond, etched or powder metal finishes.*











HAKKASAN libreria \_  
TRIS tavolini \_  
HAKKASAN bookcase \_  
TRIS coffee tables \_

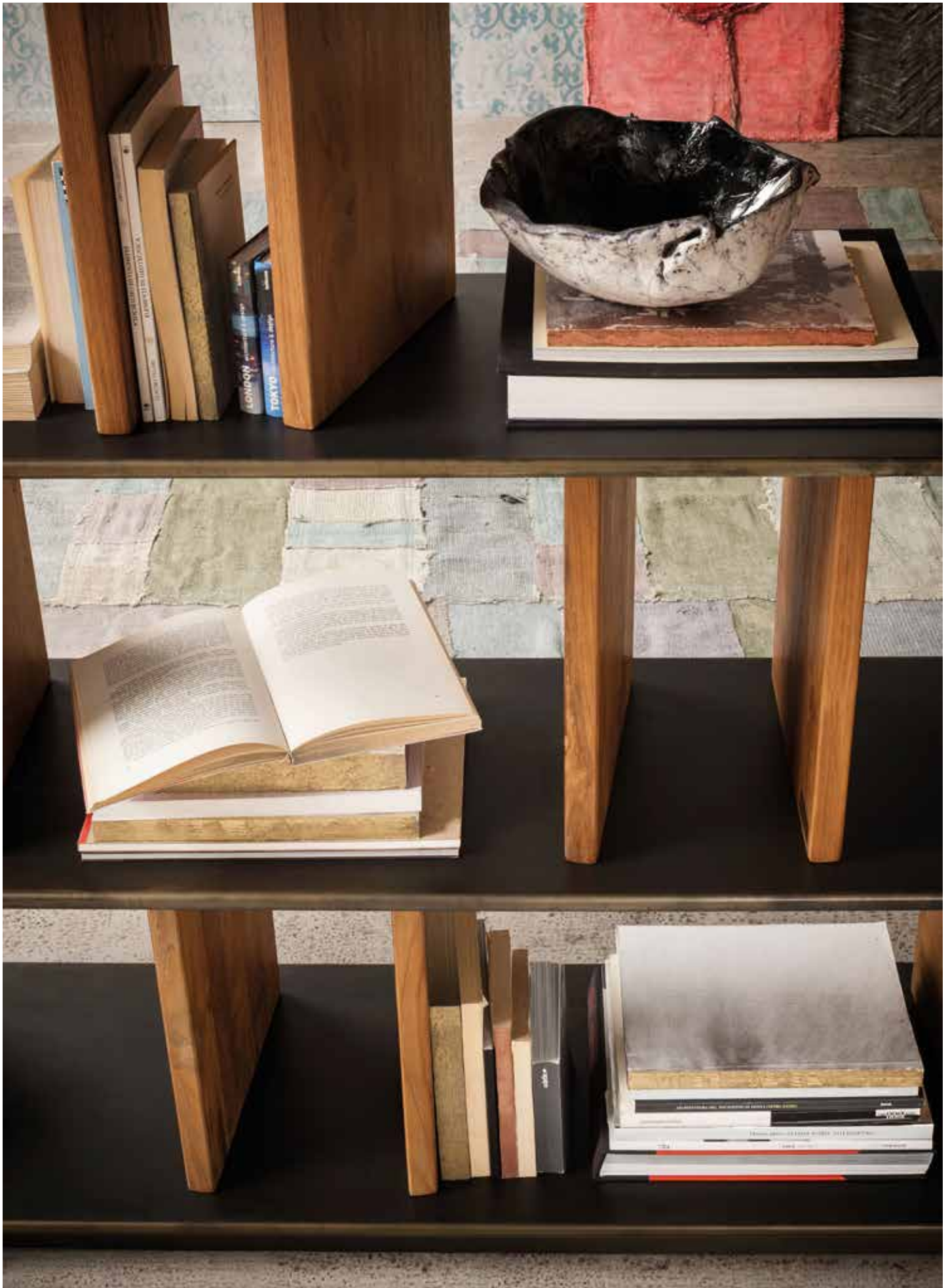



## Hakkasan

Libreria bifacciale in legno e metallo

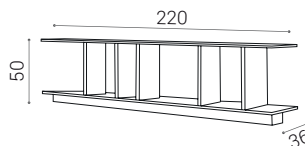
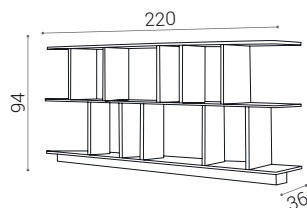
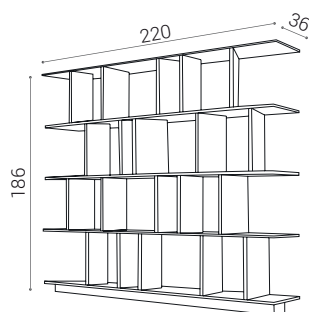

### Finiture

Metallo (A) (B)

### Finishes

metal parts

### Tramezzi

Rovere



### Partitions

Oak

Noce  
Canaletto



Canaletto  
Walnut

## La modularità di Hakkasan

Grazie alla sua modularità, la libreria di design Hakkasan è configurabile anche nella versione bassa alta 94 o 50 cm

### *Hakkasan; a modular bookcase*

*being modular, our designer HAKKASAN bookcase can also be configured in a low version with two height options, 94 or 50 cm.*

MATERIA E FINITURE  
MATERIALS AND FINISHES



# Le polveri

La verniciatura a polveri di Elite To Be, grazie all'ampia gamma di colori disponibili, permette di personalizzare con la massima libertà cromatica il proprio arredo su misura.

Usata sulle superfici metalliche allo scopo di colorarle e, al tempo stesso, di proteggerle dalla corrosione, questa finitura è particolarmente apprezzata nel settore del design da interni ed esterni per la sua linea pulita e minimale che dona un tocco di eleganza e modernità all'ambiente in cui viene utilizzato.

## *Powder coatings*

*Thanks to the wide range of colors available, Elite To Be's powder coatings allows maximum freedom for customization of tailor-made furniture accessories.*

*Used to paint metal surfaces, and at the same time, to prevent corrosion, this type of finish is favored in the fields of interior and exterior design for the elegant and modern twist of its clean and minimalist style.*



## \_Napala

NAPALA è una libreria divisoria a giorno realizzata in metallo taglio laser, le quattro altezze disponibili lo rendono un sistema modulare adatto al contenimento e alla divisione degli spazi interni della zona giorno e degli spazi pubblici. Come per la maggior parte della collezione Elite To Be, anche questo elemento è disponibile nelle finiture metalliche diamantate, acidate o a polveri

## \_Napala

*NAPALA "twisting" profile bookcase is perfect shape to grant the stability when used as a room interiors divider either at home or in public venues. Made from laser-cut metal is available in 4 different height options and finished in all metal diamond finishes nickel, bronze, brass, lead, etched or powder coated.*







LIBRERIE  
BOOKCASES



**Napala**

Libreria in metallo  
Metal modular bookcase

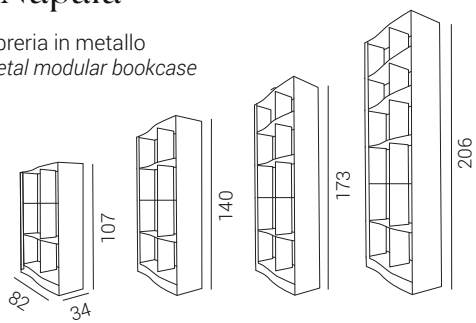

**\_Finiture**

**\_Finishes**



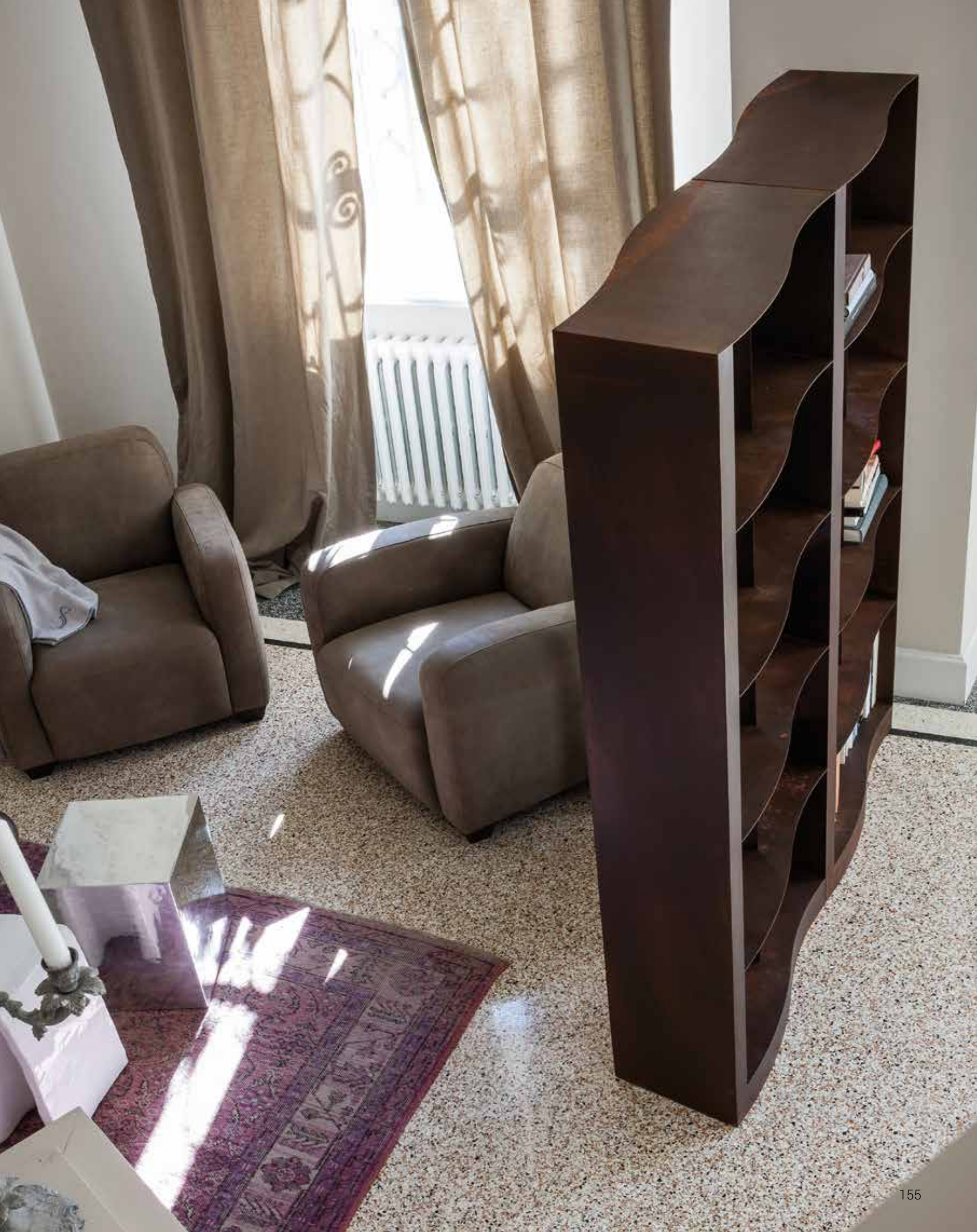

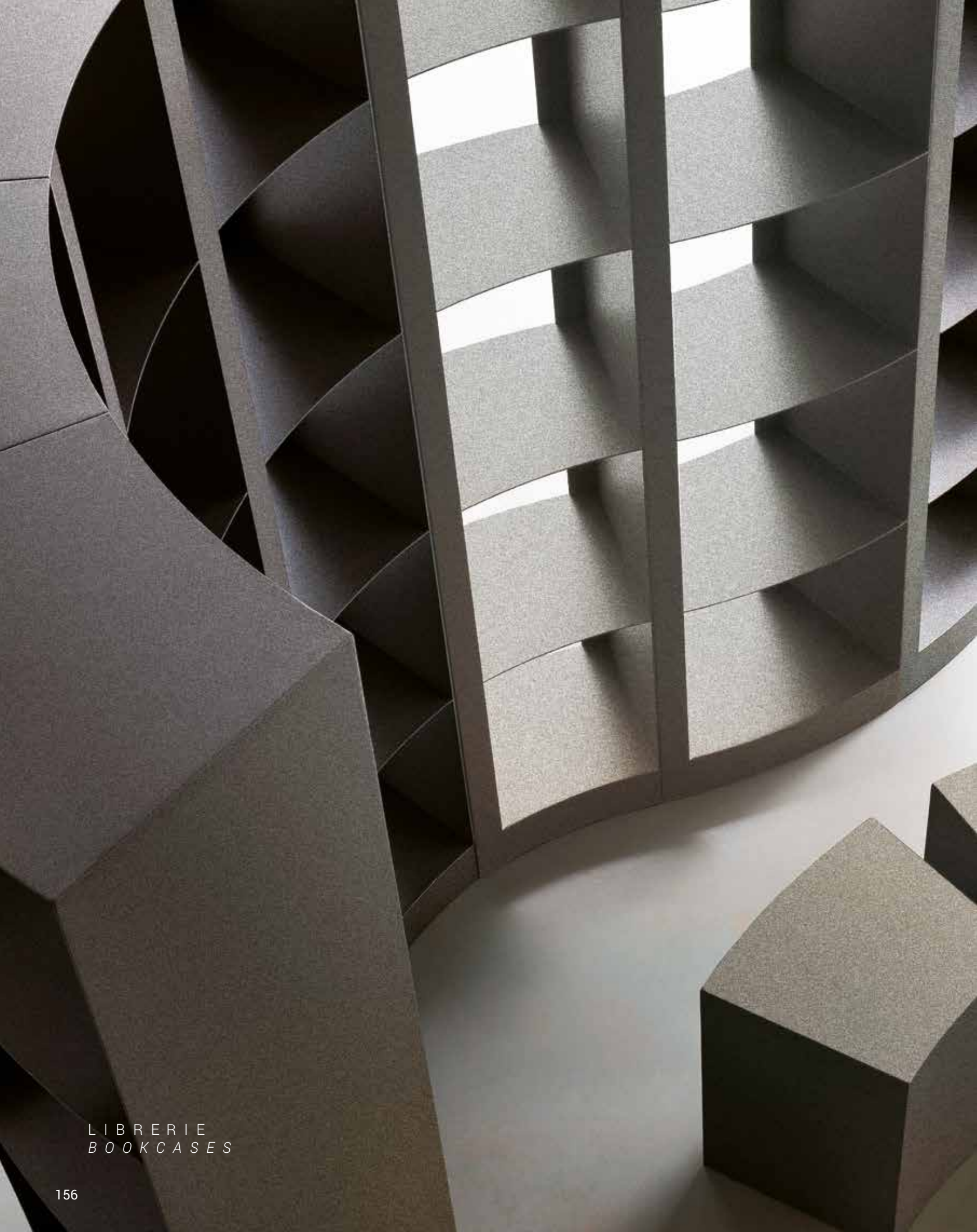

LIBRERIE  
BOOKCASES



## \_Doda

Libreria in metallo  
*Metal conic shape bookcase*

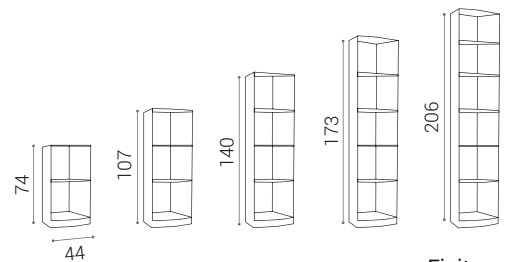

\_Finiture  
*\_Finishes*



## La componibilità di Doda

DODA è una libreria autoportante bifacciale a sezione conica, ideale per la suddivisione degli spazi mediante l'accostamento di più moduli.

Le geometrie variabili e la flessibilità sono i tratti distintivi per ambienti minimalisti di design.

### *Doda modularity*

*DODA is a conic section, two-faced free-standing bookcase that is ideal for dividing spaces by placing modules next to each other.*

*Flexibility and variable-geometry are the main characteristics of this modular bookcase; available in several metal finishes, this is a true example of modern style designed for minimalist interiors.*



LIBRERIE  
BOOKCASES



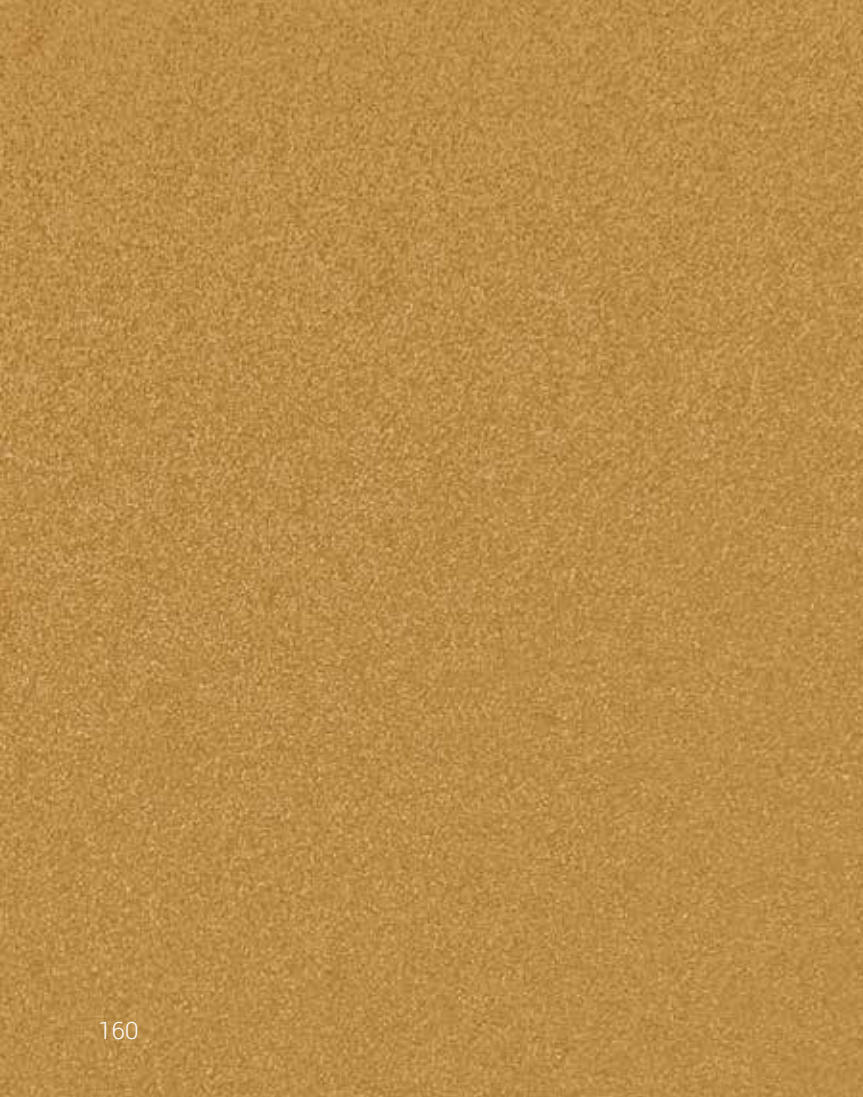



## *Diamond finishes*

*Diamond finish is a process that adds a touch of luxury to the surface of metal furniture items.*

*Being particularly bright and granular, this type of finish gives the metal surfaces a pleasing look and feel; it is by no coincidence that it is widely used in the jewelry finishes.*

*Thanks to its high resistance to wear and tear, ageing and UV radiation, the diamond finish is suitable for both indoor and outdoor furniture. It is a non-toxic finish, and its food grade is certified also in the US.*

*Available in four colors across most of Elite To Be's product lines, this finish redefines the concept of luxury be it in a traditional or in a minimalist home.*

### *The choice*

*The diamond finishes are available in the colors:*

*Nickel*

*Bronze*

*Brass*

*Lead*

## Le finiture diamantate

La finitura a diamantata è un procedimento capace di rendere preziose le superfici dei metalli

Grazie alla sua particolare luminosità e alla sua granulosità, la diamantatura conferisce un gradevole aspetto visivo e tattile alle superfici metalliche degli arredi, non a caso è una lavorazione ampiamente utilizzata nel settore dell'oreficeria.

Data l'alta resistenza all'usura, all'invecchiamento, ai raggi UVA e ai prodotti di pulizia, le finiture diamantate sono adatte sia negli arredi interni che esterni.

È una finitura non tossica, certificata per il contatto con gli alimenti anche negli Stati Uniti, Disponibile in quattro tonalità nella maggior parte delle collezioni Elite To Be, questa finitura eleva il concetto di lusso in casa sia negli ambienti tradizionali che minimalisti.

### La scelta

Le finiture diamantate sono disponibili nelle colorazioni:

Nickel

Bronzo

Ottone

Piombo



## \_Mooie

Libreria in legno e metallo  
Bookcase in wood and metal

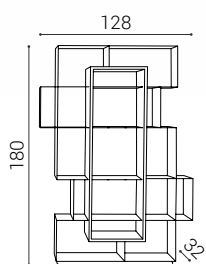

<b>_Finiture</b>		<b>_Finishes</b>	
Struttura	(A) (B) (P)	Metal frame	
Legno		<b>Wood insert</b>	
Rovere	[Silver wood sample]	Silver	Oak
Silver		Oak	
Rovere	[Oak wood sample]	Oak	
Noce	[Walnut wood sample]	Canaletto	Walnut
Canaletto		Walnut	







## *\_Mooie*

*MOOIE is a design living room bookcase that combines the warmth of wood with the purity of metals.*

*The available solutions in silver oak, natural oak or Canaletto walnut combined with the finishes of the metal structure in diamond, acid-etched or powder coating, allow a wide range of solutions suitable for any interior design style.*

## *\_Mooie*

La libreria da soggiorno di design MOOIE coniuga il calore del legno e la purezza del metallo.

Le combinazioni disponibili con inserto in rovere, rovere silver o noce canaletto, e le finiture metalliche diamantate acidate o polveri, coprono una vasta gamma di abbinamenti possibili che ben si adattano a tutti gli stili di arredamento.

# Complementi e accessori

Unici e raffinati, i complementi di Elite To Be si distinguono per le forme singolari ispirate dalla natura e per le finiture ricche.

Sono accessori per la casa di design, per chi nell'home decor ricerca la qualità del pezzo artigianale.

Che siano ciotole, vasi, appendiabiti o paraventi, mettere in casa un nostro complemento risulta essere una scelta mai banale, e tanto meno scontata.

## *Complementary Interior Accessories*

*Unique and refined, Elite To Be's furnishing accessories stand out for their distinctive shapes, inspired by Nature, and for their sophisticated finishes.*

*Our designer accessories are conceived for those who look for quality handcrafted home decor products.*

*Be they bowls, vases, coat-stands or folding screens, our accessories are no ordinary furnishing solutions for your home*





## Rainbow

Ciotola in ceramica con finitu a esterna bianca e interna bianca, bronzo o cemento.  
*Ceramic bowl with white external finish and white, bronze, or cement interior.*

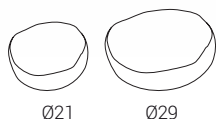

### Finiture Finishes

Esterno  
Bianco exterior  
White

Interno  
Bianco interior  
White

Bronzo  
Bronze

Cemento  
Cement

Il contrasto di colori e texture tra l'interno bianco, cemento o bronzo e l'esterno in smalto opaco bianco dà vita a RAINBOW, un oggetto dall'interessante confronto tattile e visivo.

La ruvidità o la lucentezza espresse dalle finiture e la sagomatu a irregolare fanno di questa ciotola il pezzo ideale per la decorazione di casa.

*The contrast of color and texture between the white, concrete or bronze interior and the external matt white enamel finish brings RAINBOW to life, and makes it a visually and tactilely enjoyable object. With its rough or glossy finish and its irregular shape, this bowl is the ideal designer item to decorate your home.*



## \_Cardo

Le geometrie dei vasi in ceramica CARDO sono ispirate al bocciolo dell'omonimo fiore.

In questo oggetto di design, la superficie spigolosa è ricoperta di smalto lucido carteggiato a mano per far riaffiorare il colore originale dell'argilla e creare interessanti contrasti tra le aree grezze opache e quelle lisce e lucide.

*The geometric shape of CARDO vases is inspired by the bud of the thistle flower.*

*The angular surface is first finished in gloss enamel and then sanded by hand to allow the original clay to resurface, thus creating contrast between the rough opaque areas and the smooth and shiny ones.*

Vasi in ceramica con smalto lucido carteggiato a mano  
*Ceramic vases finished in hand-sanded gloss enamel*

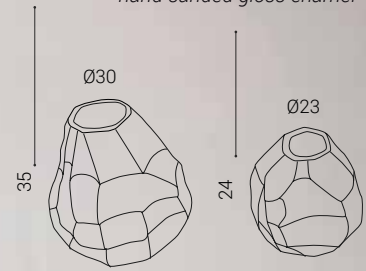

### \_Finiture

Bianco

Verde

Azzurro

### \_Finishes

Bianco

Verde

Azzurro





## La ceramica

Utilizzata fin dall'antichità, la ceramica è materia ideale per creare suppellettili e complementi d'arredo.

L'argilla, con l'aiuto di un po' d'acqua, diventa una pasta che può essere modellata per assumere la forma voluta.

In Elite To Be siamo ricorsi alla ceramica per creare vasellame e corpi illuminanti unici nelle forme e nelle finiture, tutti a ticoli realizzati e rifiniti a tiglianamente a mano.

## Ceramic

*Used since antiquity, baked clay is the ideal material to create designer furnishings and fittings.*

*Clay when mixed with water becomes a paste that can be modelled to obtain the desired shape.*

*At Elite To Be we have chosen ceramic to create pottery and light fixtures with unique shapes and finishes: all of our items are handmade by our artisans.*



## La Lun

Vaso in ceramica  
con incisioni esterne a mano

*Hand-engraved  
ceramic vase*

Così come le omonime lampade a sospensione, i tre vasi LA LUN sono caratterizzati da un corpo in ceramica dalle forme armoniose, a cui è stato conferito un aspetto più materico attraverso un'incisione manuale, un graffio, in cont'asto con la superficie liscia della ceramica di cui sono composti. L'interno bianco può essere abbinato ad un esterno bianco, cacao o sabbia.

*As for the hanging lamps of the same name, the three LA LUN vases consist of a ceramic body, harmonious in shape, hand-engraved with a particular scratch-decor technique in order to obtain a raw texture in contrast with the smooth ceramic surface. The white interior can be combined with a white, cocoa or sand exterior finish.*

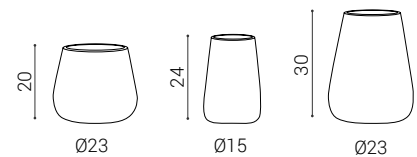

### \_Finiture

Interno  
Bianco



*interior*

*White*

### \_Finishes

Esterno

Bianco



*Bianco*

Sabbia



*Sabbia*

Cacao



*Cacao*

COMPLEMENTI E ACCESSORI  
COMPLEMENTS AND ACCESSORIES

Realizzato in ottone  
interamente battuto a mano,  
verniciato e spazzolato, il  
vaso GONG è caratterizzato  
dall'armonia tra forme e  
proporzioni.

Il design iconico di questo  
complemento d'arredo,  
dona un senso di pace e di  
equilibrio, in grado di portare  
ad ogni ambiente un tocco di  
sostanziosa eleganza

*Made of hand-wrought  
brass, painted and  
brushed by hand, GONG is  
a vase characterized by  
the harmony of its shape  
and proportions. The  
iconic design of this  
modern furnishing item  
conveys a sense of peace  
and balance and brings  
sophisticated elegance to  
any type of interiors.*



## \_Gong

Vasi in ottone inciso  
*Hand-engraved brass vases*

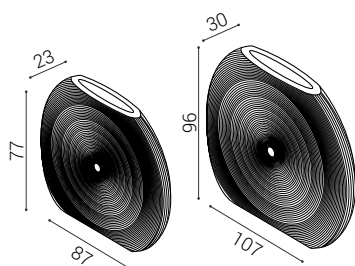

\_Finiture      \_Finishes  
Ottone      Brass





- \_ TERNO specchi
- \_ STRATOS madia

- \_ TERNO mirrors
- \_ STRATOS sideboards



## \_Terno

Set di specchi con  
cornice in ferro

*Set of mirrors  
with iron frame*

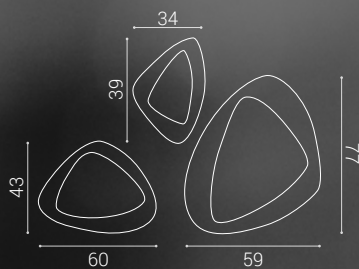

\_Finiture \_Finishes



La forma degli specchi SDQMN esprime dinamicità attraverso la lamiera modellata a mano nei bordi triangolari sbandati.

Singolare e di particolare pregio, la piegatura del bordo ottenuta tramite l'utilizzo di fiamma ossidrica

Sono inoltre disponibili tutte le varianti di finiture metalliche diamantate come il nickel, il bronzo, l'ottone e il piombo oltre alle varianti a polveri oppure ferro naturale con le bruciature della fiamma ossidrica

*The shape of the three mirrors conveys dynamism through the rounded edges of the triangular sheet metal framework. Unique and precious, the mirror finish of the framework is obtained by using an oxyhydrogen flame. These three mirrors are available in all the satin and diamond finishes, such as: nickel, bronze, brass and lead as well as flame-finished iron and satin verdigris.*

Il paravento THE FAMILY si compone di tre elementi pieghevoli ricavati da lame di metallo tagliate con la fiamma ossidrica e uniti con cerniere fatte a mano.  
Dipinto solo da un lato, presenta dall'altro una finitura manuale corten.

*THE FAMILY is a folding screen consisting of three folding pieces, made of flame-cut metal plates, joined together by hand-made hinges.  
One side is painted while the other is hand-finished in corten.*

## \_The Family

Paravento in metallo sagomato, saldato e acidato artigianalmente  
*Metal folding screen shaped, welded and etched by hand*

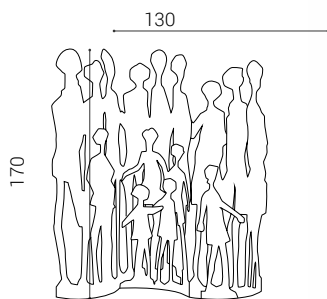

### \_Finitura

Ferro ossidato con sfumature a colori manuale

### \_Finishes



Oxidized iron with manual color shades









## La Vit

Scultura in fusione di alluminio rifinita a mano.

*Hand-finished cast aluminum vine tree sculpture*

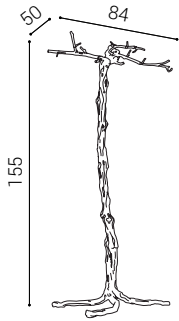

Ispirati dalla nostra terra nasce **LA VIT**, una scultura in fusione di alluminio colata artigianalmente con maestria e amore come il lavoro nei vigneti.

La Vit è un complemento artigianale nato per arredare le cantine e gli ambiti conviviali in modo originale e prestigioso.

*The design of LA VIT was inspired by our "wine land": a cast aluminum sculpture handcrafted with the same mastery and passion required by work in the vineyards.*

*LA VIT is an handcrafted item conceived as an original and prestigious piece of furniture for wineries and other convivial environments.*



# Dimensioni

Nelle pagine seguenti sono riportate tutte le dimensioni dei nostri complementi Unici To Be. Buona consultazione!

## *Dimensions*

*The following pages show all the dimensions of our Unici To Be accessories. Enjoy consultation!*



# Tavoli

## Tables

Ala pg.14

Massiccio  
Solid wood

**\_Misure \_Dimensions**  
220 x 100 -105 x H.74/78  
240 x 100 -105 x H.74/78  
270 x 100 -105 x H.74/78  
300 x 100 -105 x H.74/78

**\_Finiture \_Finishes**  
Basamento \_Basement

(A) (B) (P)

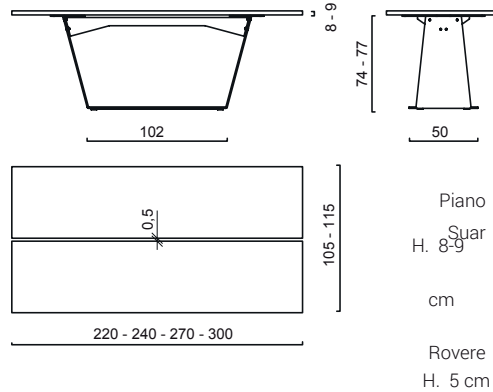

Piano Top  
Suar H. 8-9  
cm  
Rovere H. 5 cm

Suar H. 8-9 cm  
Oak H. 5 cm

Ala Jr. B pg.20

Massiccio  
Solid wood

**\_Misure \_Dimensions**  
160 x 85 x H.74  
180 x 85 x H.74  
200 x 93 x H.74

**\_Finiture \_Finishes**  
Basamento \_Basement

(A) (B) (P)

Piano Top  
Suar H. 4 cm Suar H. 4 cm

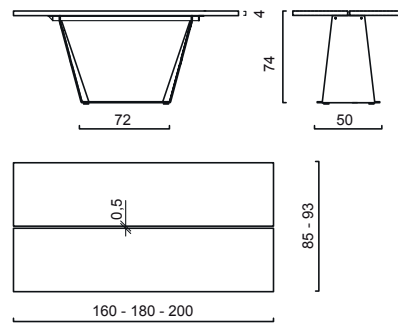

Squadrato  
Square

**\_Misure \_Dimensions**  
140 x 80 x H.73  
160 x 90 x H.73  
180 x 90 x H.73  
200 x 90 x H.73

**\_Finiture \_Finishes**  
Basamento \_Basement

(A) (B) (P)

Piano Top (F) (G)  
Impiallacciato o Argilla wood veneered or clay

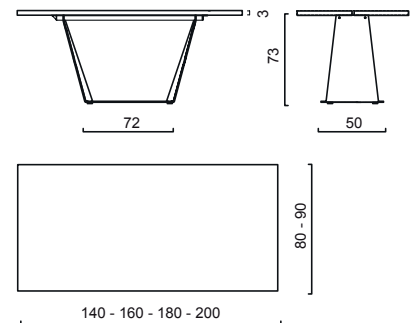

Massellato  
Solid Wood Edge

**\_Misure \_Dimensions**  
160 x 80 x H.74  
180 x 90 x H.74  
200 x 100 x H.74

**\_Finiture \_Finishes**  
Basamento \_Basement

(A) (B) (P)

Piano Top (E)

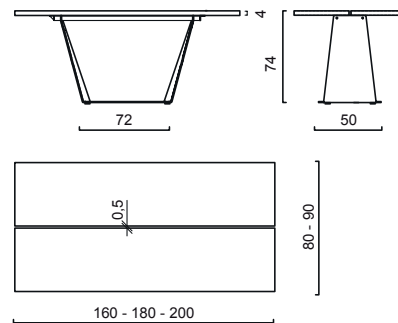

Romboidale  
"Diamond" shape

**\_Misure \_Dimensions**  
160 x 80 x H.74  
180 x 90 x H.74  
200 x 100 x H.74

**\_Finiture \_Finishes**  
Basamento \_Basement

(A) (B) (P)

Piano Top (G)

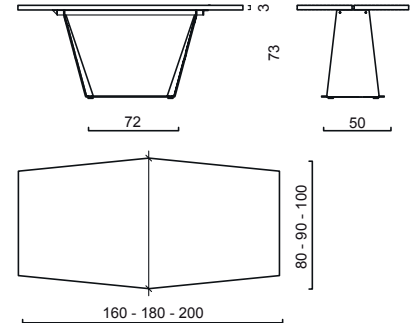

Ala Jr. A pg.24

Massiccio  
Solid wood

**\_Misure \_Dimensions**  
80 x 80 x H.74

**\_Finiture \_Finishes**  
Basamento \_Basement

(A) (B) (P)

Piano Top  
Suar H. 4 cm Suar H. 4 cm

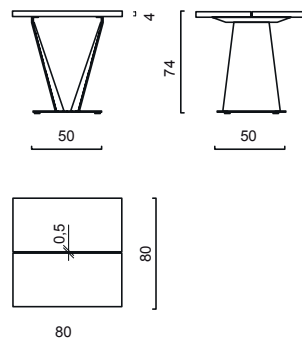

Squadrato  
Square

**\_Misure \_Dimensions**  
140 x 80 x H.73  
100 x 100 x H.73

**\_Finiture \_Finishes**  
Basamento \_Basement

(A) (B) (P)

Piano Top (F) (G)  
impiallacciato/argilla wood veneered or clay

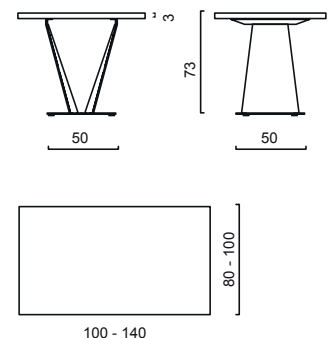

# Tables

## Dasar pg. 28

Massiccio  
Solid wood

**\_Misure \_Dimensions**

220 x 100 -105 x H.74/78  
240 x 100 -105 x H.74/78  
270 x 100 -105 x H.74/78  
300 x 100 -105 x H.74/78

**\_Finiture \_Finishes**  
Basamento \_Basement

(A) (B) (P)

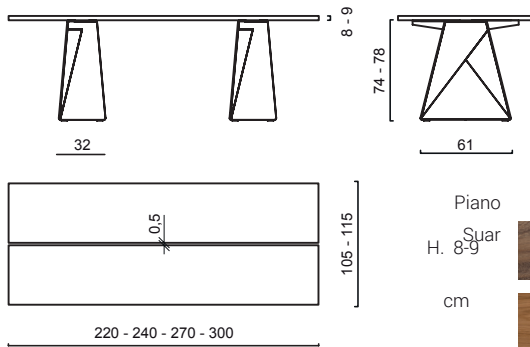

Piano Top  
Suar H. 8-9 Suar H. 8-9 cm  
Rovere H. 5 cm Oak H. 5 cm

## Dasar Jr. pg. 36

Massiccio  
Solid wood

**\_Misure \_Dimensions**

160 x 85 x H.74  
180 x 85 x H.74  
200 x 93 x H.74

**\_Finiture \_Finishes**  
Basamento \_Basement

(A) (B) (P)

Piano Top  
Suar H. 4 cm Suar H. 4 cm

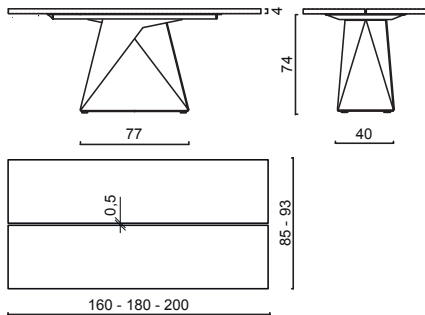

Squadrato  
Square

**\_Misure \_Dimensions**

140 x 80 x H.73  
160 x 90 x H.73  
180 x 90 x H.73  
200 x 90 x H.73

**\_Finiture \_Finishes**  
Basamento \_Basement

(A) (B) (P)

Piano Top (F) (G)  
Impiallacciato o Argilla wood veneered or clay

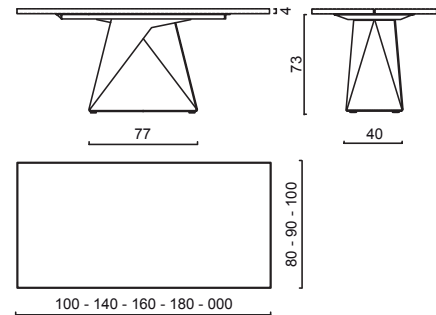

Massellato  
Solid Wood Edge

**\_Misure \_Dimensions**

160 x 80 x H.74  
180 x 90 x H.74  
200 x 100 x H.74

**\_Finiture \_Finishes**  
Basamento \_Basement

(A) (B) (P)

Piano Top (E)

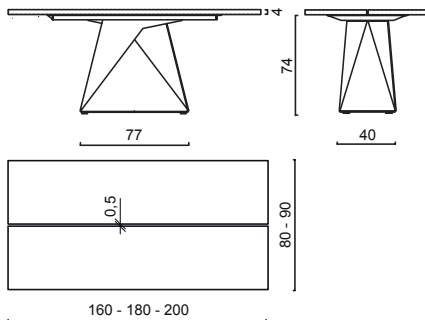

Romboidale  
"Diamond" shape

**\_Misure \_Dimensions**

160 x 80 x H.74  
180 x 90 x H.74  
200 x 100 x H.74

**\_Finiture \_Finishes**  
Basamento \_Basement

(A) (B) (P)

Piano Top (G)

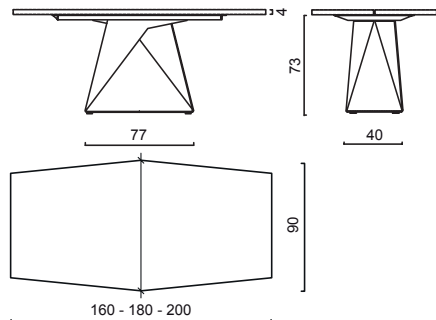

## Trog pg. 44

Massiccio  
Solid wood

**\_Misure \_Dimensions**

220 x 100 -105 x H.74/78  
240 x 100 -105 x H.74/78  
270 x 100 -105 x H.74/78  
300 x 100 -105 x H.74/78

**\_Finiture \_Finishes**  
Basamento \_Basement

(A) (B) (P)

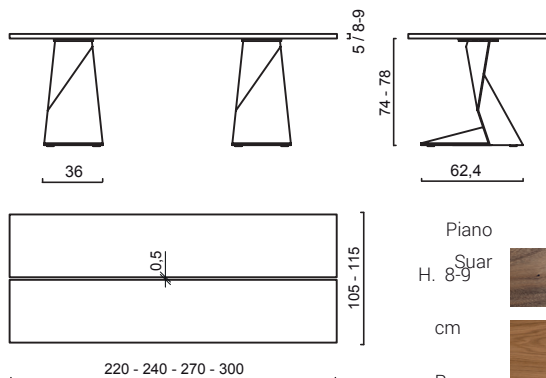

Piano Top  
Suar H. 8-9 Suar H. 8-9 cm  
Rovere H. 5 cm Oak H. 5 cm

# Tavoli

## Tables

### Trog Jr. pg. 46

Massiccio  
*Solid wood*

*\_Misure \_Dimensions*

160 x 85 x H.74  
180 x 85 x H.74  
200 x 93 x H.74

*\_Finiture \_Finishes*  
Basamento *\_Basement*

(A) (B) (P)

Piano *Top*  
Suar *Suar*  
H. 4 cm *H. 4 cm*

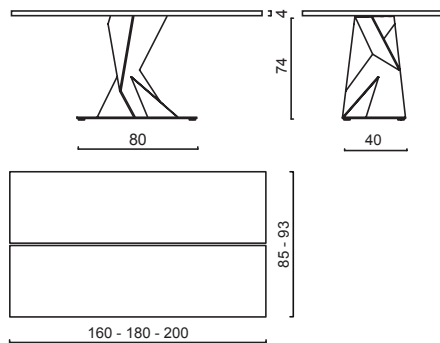

Squadrato  
*Squared*

*\_Misure \_Dimensions*

140 x 80 x H.73  
160 x 90 x H.73  
180 x 90 x H.73  
200 x 90 x H.73

*\_Finiture \_Finishes*  
Basamento *\_Basement*

(A) (B) (P)

Piano *Top* (F) (G)  
Impiallacciato o Argilla *\_wood veneered or clay*

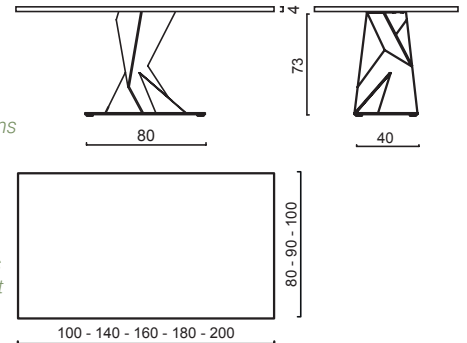

Massellato  
*Solid Wood Edge*

*\_Misure \_Dimensions*

160 x 80 x H.74  
180 x 90 x H.74  
200 x 100 x H.74

*\_Finiture \_Finishes*  
Basamento *\_Basement*

(A) (B) (P)

Piano *Top* (E)

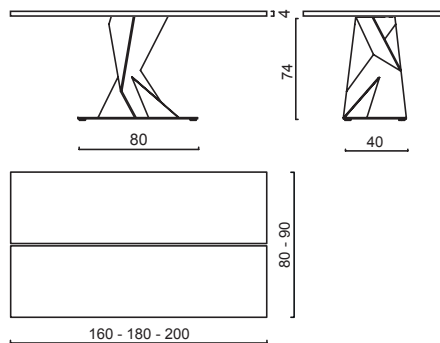

Romboidale  
*"Diamond" shape*

*\_Misure \_Dimensions*

160 x 80 x H.74  
180 x 90 x H.74  
200 x 100 x H.74

*\_Finiture \_Finishes*  
Basamento *\_Basement*

(A) (B) (P)

Piano *Top* (G)

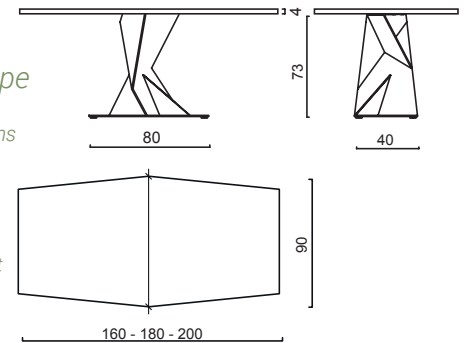

### Noa pg.50

Massiccio  
*Solid Wood Edge*

*\_Misure \_Dimensions*

220 x 110 x H.75  
240 x 120 x H.75  
270 x 120 x H.75

*\_Finiture \_Finishes*

Gambe *Aluminum* (A) (C)  
in alluminio *legs*

Piano *Top*  
Teak *Teak*  
Teak riciclato *Recycled Teak*

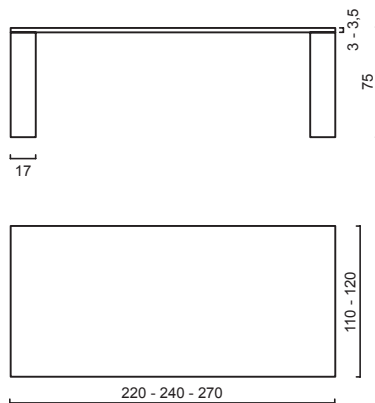

Squadrato  
*Squared*

*\_Misure \_Dimensions*

140 x 140 x H.75  
160 x 90 x H.75  
180 x 90 x H.75  
200 x 100 x H.75

*\_Finiture \_Finishes*

Gambe *Aluminum* (A) (C)  
in alluminio *legs*

12 x 12 x H.71  
15 x 15 x H.71  
17 x 17 x H.71

Piano *Top* (F) (G)

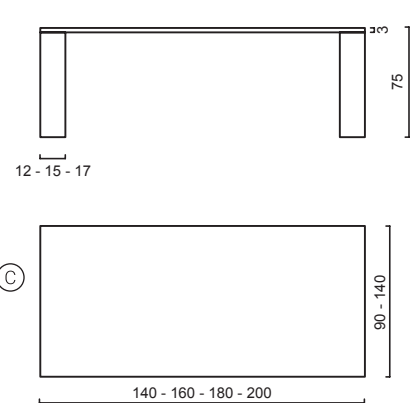

### Noa Jr. pg. 62

Squadrato  
*Squared*

*\_Misure \_Dimensions*

140 x 140 x H.75  
140 x 80 x H.75  
160 x 90 x H.75  
180 x 90 x H.75  
200 x 100 x H.75

*\_Finiture \_Finishes*

Gambe *Aluminum* (A) (B) (P)  
in alluminio *legs*  
15 x 15 x H.71

Piano *Top* (F) (G)

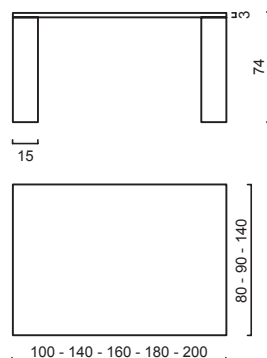

# Sedie Chairs

**Giulia** pg. 37

**\_Finiture \_Finishes**

 Ferro antracite  
Iron Anthracite

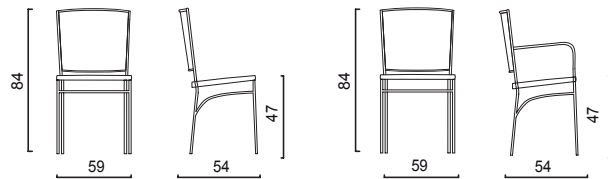

**Giuly** pg. 27

**\_Finiture \_Finishes**

Fusto *Metal Frame*  
 Ferro Antracite  
Iron Anthracite

Seduta e schienale  
*Seat and back*

 Rattan  
Rattan

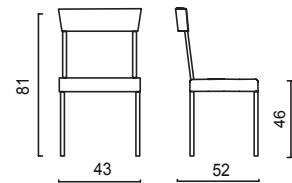

**Byron** pg. 30

**\_Finiture \_Finishes**

(A) (B) (C)

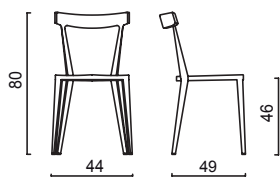

**Noa** pg. 60

**\_Finiture \_Finishes**

Fusto *Metal Frame*

(A) (C) (P)

Seduta *Wood Seat*

 Teak  
Teak

 Teak Silver  
Teak Silver

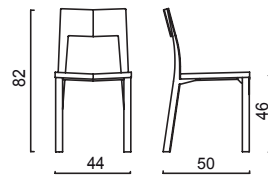

**Trog** pg. 48

**\_Finiture \_Finishes**

Fusto *Metal Frame*

(A) (B) (P)

Seduta e schienale  
*Seat and back*

 Eco\_pelle testa di moro  
Faux Leather brown

 Eco\_pelle nera  
Faux Leather black

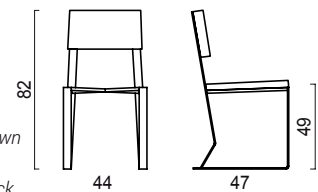

**Kaalta** pg. 64

**\_Finiture \_Finishes**

Base *Metal Frame*

(B) (P)

Seduta *Wood Seat*

 Suar  
Suar

 Rovere  
Oak

(B) (F) (G)

(D) \*Solo su richiesta \*Only on Special Request

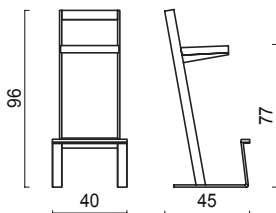

**Kadra** pg. 66

**\_Finiture \_Finishes**

Base *Metal Frame*

(B) (P)

Seduta

 Suar  
Suar

 Rovere  
Oak

(F) (G)

(D) \*Solo su richiesta \*Only on Special Request

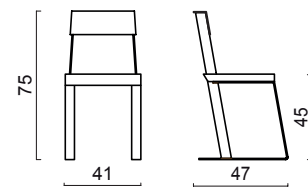

**Kalonga** pg. 68

**\_Finiture \_Finishes**

Base *Metal Frame*

(B) (P)

Seduta *Wood Seat*

 Suar  
Suar

 Rovere  
Oak

(B) (F) (G)

(D) \*Solo su richiesta \*Only on Special Request

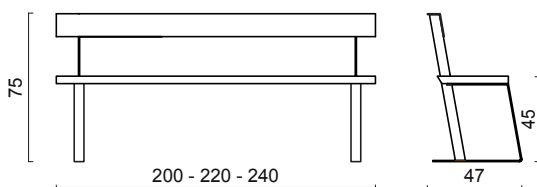



# Tavolini e Sgabelli

## Coffee tables and Stools

**Al** pg. 78  
\_Finiture \_Finishes

(A) (B) (P)

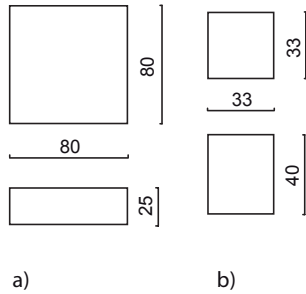

**Otto Tall&Low** pg. 74  
\_Finiture \_Finishes

(A) (C) (P)

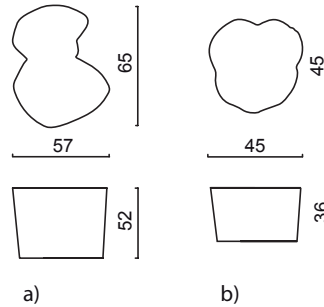

**Otto** pg. 76  
\_Finiture \_Finishes

(A) (C) (P)

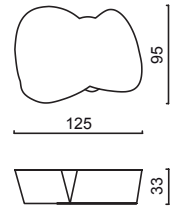

**Fil De Fer** pg. 80  
\_Finiture \_Finishes



Grigio Antracite  
Grey Anthracite



Bianco  
White

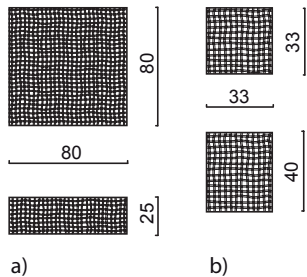

**Tris** pg. 86  
\_Finiture \_Finishes

(A) (B) (P)

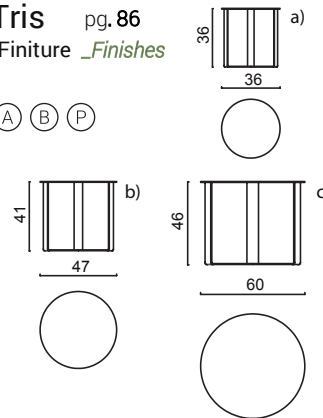

**Taolin** pg. 65  
\_Misure \_Dimensions

45 x 45 x H.108  
45 x 60 x H.108  
60 x 60 x H.108

\_Finiture \_Finishes

Basamento (A) (B) (P)  
Basement

Piano  
Top

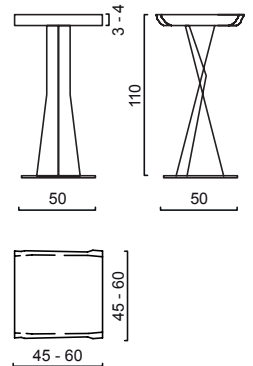
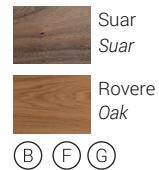

**Kross** pg. 90  
\_Finiture \_Finishes



Suar  
Suar

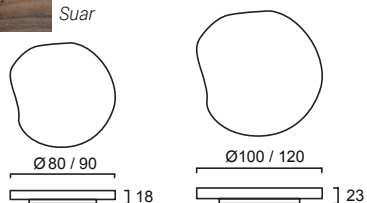

**Hug** pg. 88  
\_Finiture \_Finishes



Abete Naturale  
Natural Fir



Abete Grigio  
Grey Fir

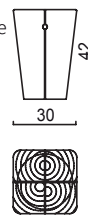

**Ketil** pg. 84  
\_Finiture \_Finishes

(A) (B) (P)

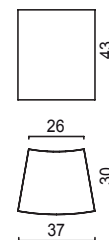

**Igloo** pg. 96  
\_Finiture \_Finishes

Alluminio lucido  
Aluminum Polished



Alluminio smerigliato  
Frosted Aluminum

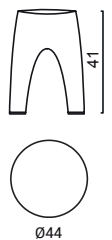

**Kobe** pg. 92  
\_Finiture \_Finishes



Radica di Teak  
Teak Burl

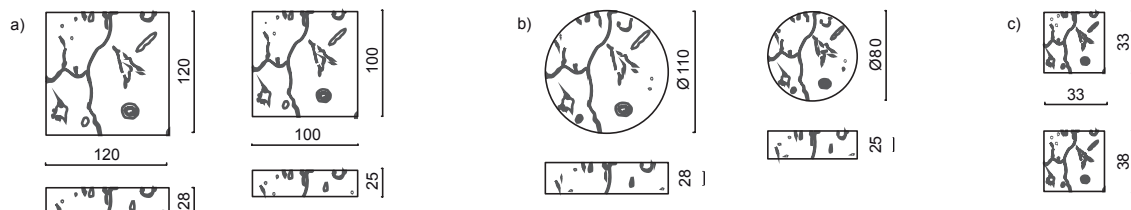

# Madie

## Sideboards

### Stratos pg. 102

#### \_Finiture \_Finishes

Struttura Metal structure

(A) (B) (P)

Ante Doors

Mosaico Exclusive  
Mosaic Exclusive

Terrazzo Veneziano  
Venetian Terrace

Mosaico Terra  
Mosaic Earth

Argilla  
Clay

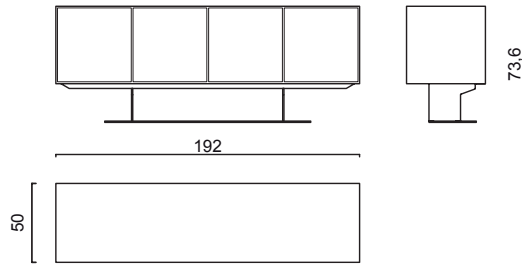

### Convivium slim pg. 114

#### \_Finiture \_Finishes

Interno  
Argilla grigio

Interior  
Grey Clay

Esterno  
Rovere Silver

Exterior  
Silver Oak

Rover Nero

Natural Oak

Noce Canaletto

Canaletto Walnut

Esterno telaio Metal Frame

(A) (P)

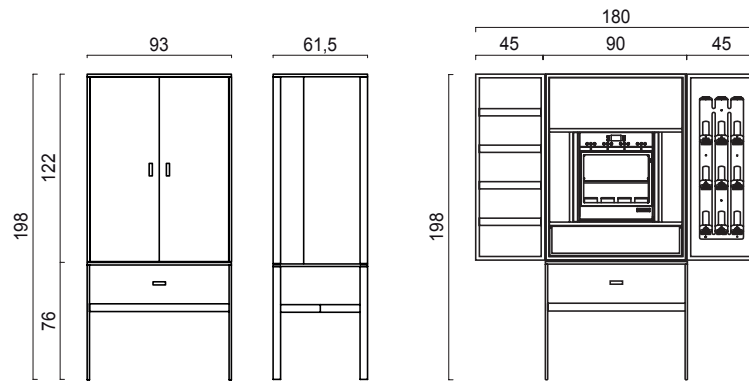

### Convivium bold pg. 119

#### \_Finiture \_Finishes

Interno  
Rovere Silver

Exterior  
Silver Oak

Rovere

Oak

Noce Canaletto

Canaletto Walnut

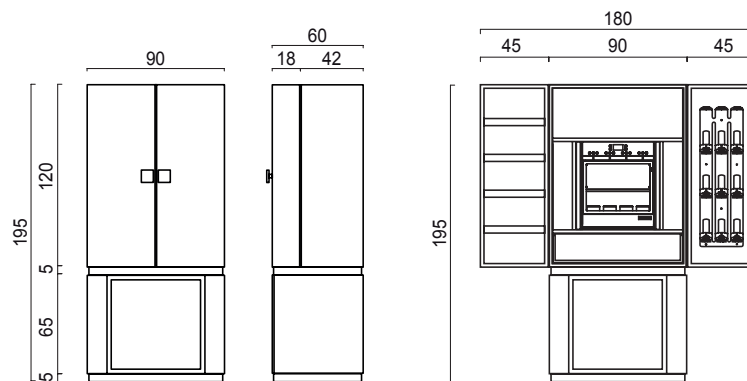

# Illuminazione

## Lighting

### Baloon pg. 123

#### \_Finiture \_Finishes

Interno  
Bianco

Interior  
White

Foglia Oro

Gold Leaf

Foglia Argento

Silver Leaf

Esterno  
Exterior

(A) (B) (P)

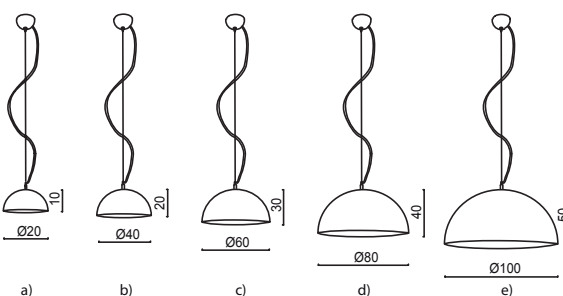

### La Lun pg. 171

#### \_Finiture \_Finishes

Interno  
Bianco

Interior  
White

Foglia Oro

Gold Leaf

Esterno  
Bianco

Exterior  
White

Sabbia

Sand

Cacao

Cocoa

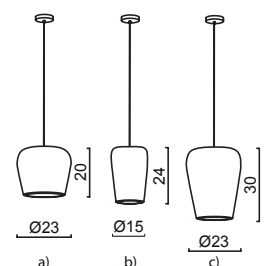

### Tuli pg. 132

\_Finiture \_Finishes

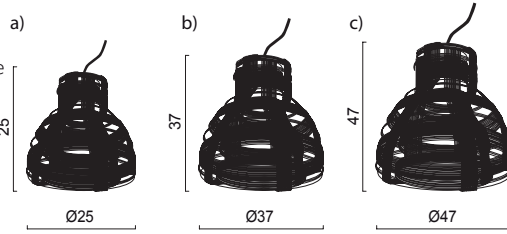

### Arboj pg. 138

\_Finiture \_Finishes

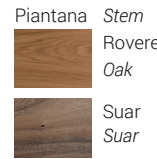

Base Metal base  
(A) (B) (P)

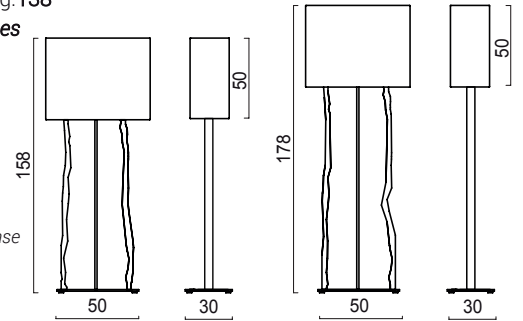

### Nest & Nest Midi pg. 126

\_Finiture \_Finishes

Interno  
Interior

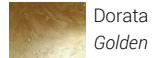

Esterno  
Exterior

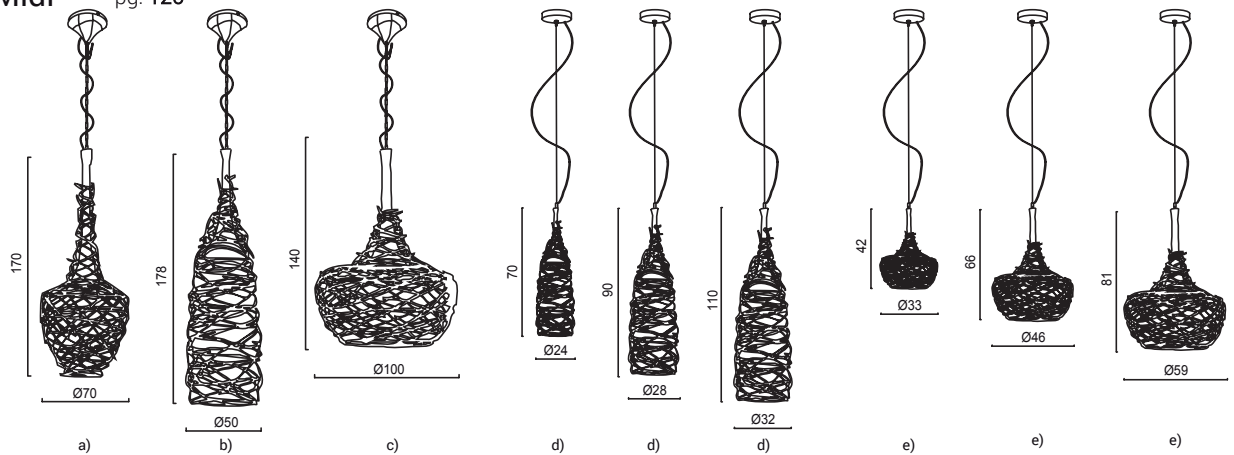
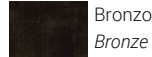

### Gami pg. 130

\_Finiture \_Finishes

Interno  
Interior



Foglia oro  
Gold Leaf

Foglia argento  
Silver Leaf

Esterno  
Exterior

Cemento  
Cement

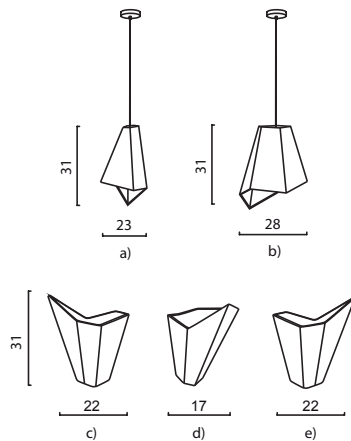

### Lenti pg. 124

\_Finiture \_Finishes

Interno  
Interior



Esterno  
Exterior

(A) (B) (P)

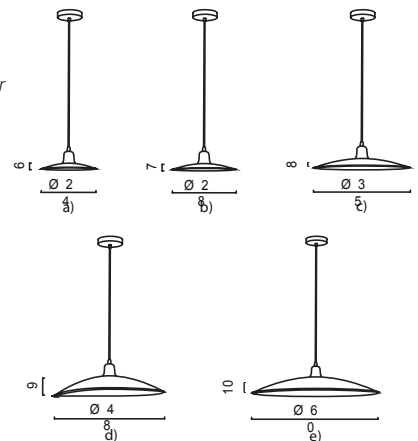

### Ekflam pg. 134

\_Finiture \_Finishes

Interno  
Interior



Esterno  
Exterior

Bronzo antico  
Antique Bronze

(A) (B)

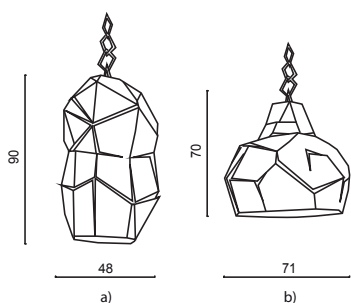

### Goblet pg. 140

\_Finiture \_Finishes

Interno  
Interior

(A) (B) (P)

Esterno  
Exterior

(A) (B) (P)

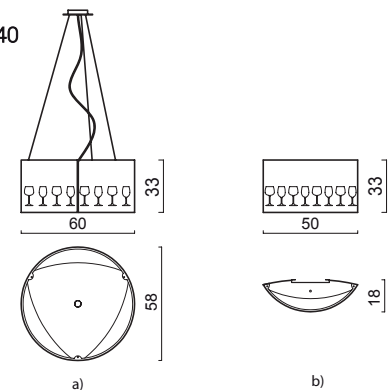

# Librerie

## Bookcases

### Napala pg. 152

*\_Finiture \_Finishes*

(A) (B) (P)

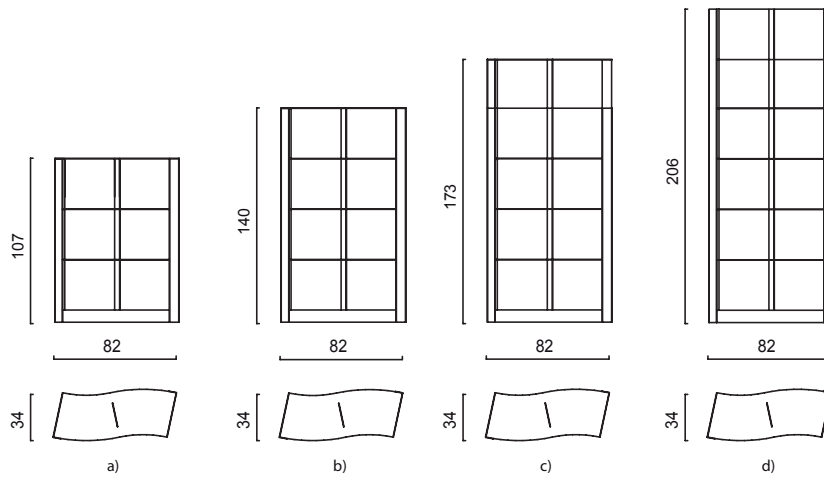

### Doda pg. 156

*\_Finiture \_Finishes*

(A) (B) (P)

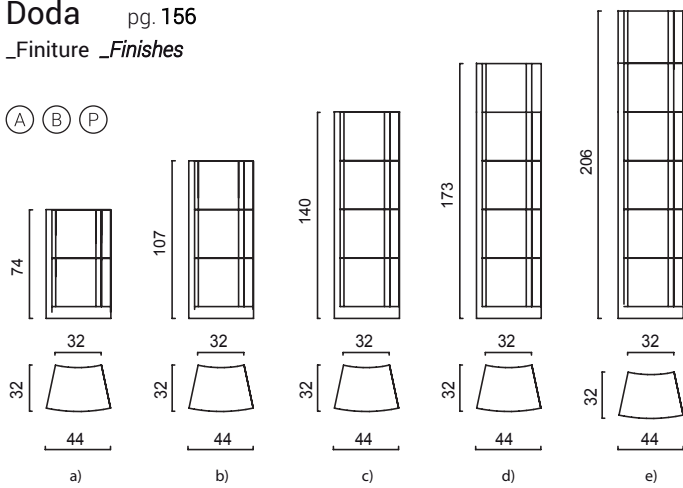

### Mooie pg. 162

*\_Finiture \_Finishes*

Struttura in metallo  
*Metal Structure*

(A) (B) (P)

Struttura in legno  
*Wood Insert & Divider*

Rovere Silver		Silver Oak
Rovere		Oak
Noce Canaletto		Canaletto Walnut

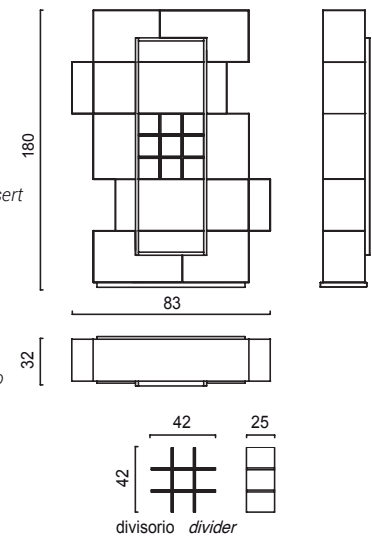

### Hakkasan pg. 144

*\_Finiture \_Finishes*

Metallo *Metal elements*

(A) (B) (P)

Tramezzi  
*Wood partitions*

Rovere		Oak
Noce Canaletto		Canaletto Walnut

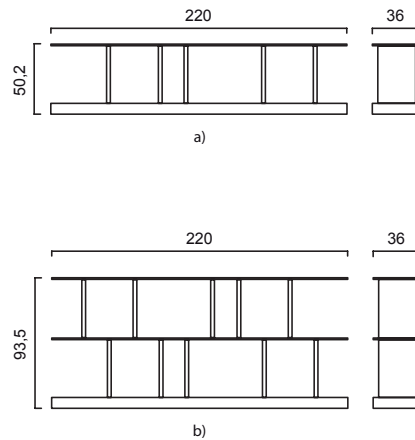

# Complementi e Accessori

## Complements Accessories

### Rainbow pg. 168

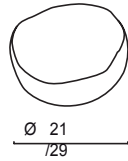

**\_Finiture** **\_Finishes**

Interno		Interior
Bianco		White
Bronzo		Bronze
Cemento		Cement
Esterno		Exterior
Bianco		White



### Cardo pg. 169



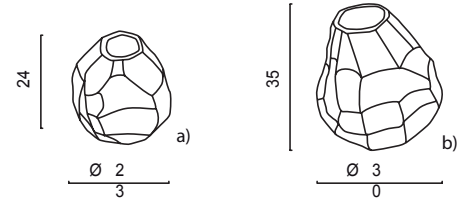

**\_Finiture** **\_Finishes**

		Bianco
		White
		Verde
		Green
		Azzurro
		Sky Blue



### La Lun pg. 171

**\_Finiture** **\_Finishes**

Interno		Interior
Bianco		White
Esterno		Exterior
Bianco		White
Sabbia		Sand
Cacao		Cocoa

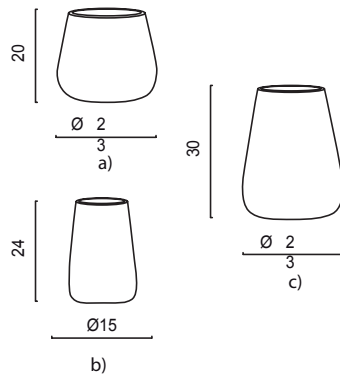

### Gong pg. 172

**\_Finiture** **\_Finishes**

		Ottone
		Brass

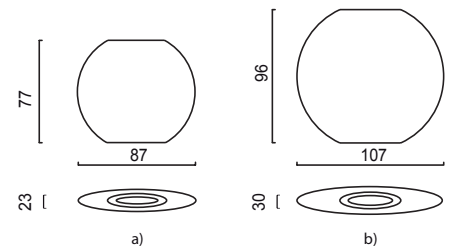

### Terno pg. 174

**\_Finiture** **\_Finishes**

Metallo		_Metal Frame
(A) (B) (P)		

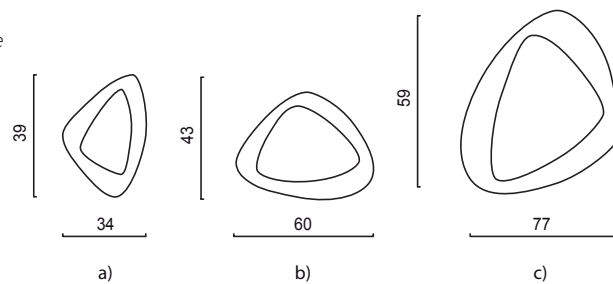

### La Vit pg. 179

**\_Finiture** **\_Finishes**

Scultura in fusione di alluminio, con stampo in terra, rifinita a mano.

*Sculptural clothes hanger in cast aluminium, finished by hand*

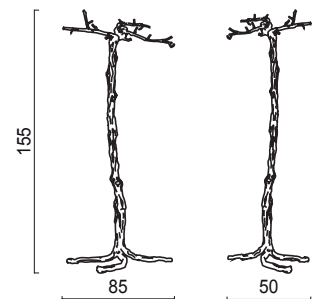

### The Family pg. 176

**\_Finiture** **\_Finishes**



Ferro ossidato con sfumature a colori manuale

*Dividing screen made of bladed iron, cut with a blowtorch and hand painted.*

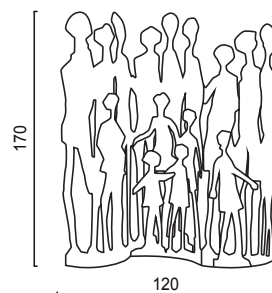

# Materiali e finiture

I materiali sono uno dei punti cardine della nuova collezione Elite To Be.

Materiali autentici come il legno nelle sue differenti essenze, con la profondità delle sue venature ed il calore di una materia viva.

Superfici metalliche estremamente eleganti e sofisticate come il nickel, il bronzo, l'ottone e il piombo.

Piani e rivestimenti in argilla naturale dove l'increspatura e la rugosità diventano il valore aggiunto di questa esperienza sensoriale e infine la riscoperta di lavorazioni artigianali passate, come il mosaico in pietra, rivisitate in chiave moderna e capaci di creare pezzi unici e inimitabili.



## *Materials and finishes*

*Materials are one of the cornerstones of the new Elite To Be collection.*

*Authentic materials such as wood in its different essences, with the depth of its veins and the warmth perceived by solid wood.*

*Extremely elegant and sophisticated diamond metal surfaces such as nickel, bronze, brass and lead.*

*The ripples and roughness of the clay finish on the table tops and on the panels surface become the added value of this sensory experience and the rediscovery of craftsmanship from the past, such as the stone mosaic, revisited in a modern key and capable of creating unique and inimitable.*

# Peculiarità dei legni masselli

I prodotti di Elite, TO BE in legno massello sono pezzi unici numerati di alto valore composti da pezzi interi, nel caso del legno di suar, o da pezzi di massello di varie larghezze incollati tra loro, nel caso dei legni di rovere e teak.

I legni utilizzati per produrre questi articoli necessitano di una lunga preparazione e vengono sottoposti ad un processo di essiccazione che avviene in atmosfera controllata con un grado di umidità media del 9% ed una tolleranza adeguata.

La loro unicità consiste nella varietà di venature, di colori e di profumi che rendono il prodotto esclusivo. Per questo motivo differenze di tonalità tra le varie parti del mobile non sono da considerarsi difetti, ma caratteristiche naturali e distintive del materiale.

Il legno massello è una materia viva: per tutto il suo ciclo di vita interagisce con l'ambiente circostante restando sensibile alle variazioni climatiche, al calore e al grado di umidità dell'aria. Crepe, fessurazioni e altri mutamenti superficiali nel corso del tempo sono conseguenze del naturale assestamento del legno in relazione alle diverse condizioni ambientali e non possono costituire motivo di reclamo.

Per una corretta cura del materiale, bisogna evitare di posizionare i prodotti vicino a fonti dirette di calore come stufe, caminetti, termosifoni o termoconvettori o alla luce diretta del sole ed è necessario mantenere nell'ambiente un'umidità relativa ideale intorno al 50% - 55%.

Nei tavoli in massello incollati in rovere e teak si possono verificare differenze di spessore di qualche millimetro tra i vari pezzi che compongono il top dovuti a movimenti naturali tipici del legno massello. Piccole fessurazioni possono essere chiuse con un apposito "stucco a cera" in formato di stick in varie colorazioni facilmente reperibile in commercio o presso i punti vendita autorizzati Elite To Be. Si consiglia di usare l'ecostucco monocomponente ad acqua e di seguire attentamente le istruzioni d'uso.

I piani in pezzo unico si ricavano da tronchi di albero interi tagliati a metà, pertanto le dimensioni possono variare rispetto a quelle generiche indicate a listino.

Nel caso in cui si necessiti di misure precise, si prega di inoltrare richiesta specifica all'atto dell'ordinazione.

## *Solid wood, as is.....*

*Materials are one of the cornerstones of the new Elite To Be collection.*

*Authentic materials such as wood in its different essences, with the depth of its veins and the warmth perceived by solid wood.*

*Extremely elegant and sophisticated diamond metal surfaces such as nickel, bronze, brass and lead.*

*The ripples and roughness of the clay finish on the table tops and on the panels surface become the added value of this sensory experience and the rediscovery of craftsmanship from the past, such as the stone mosaic, revisited in a modern key and capable of creating unique and inimitable.*

Suar

Suar



Teak

Teak



Teak riciclato

Teak recycled



Rovere

Oak









# Finiture metalliche

## Metal Finishes

### (A) Diamantati *Diamond*

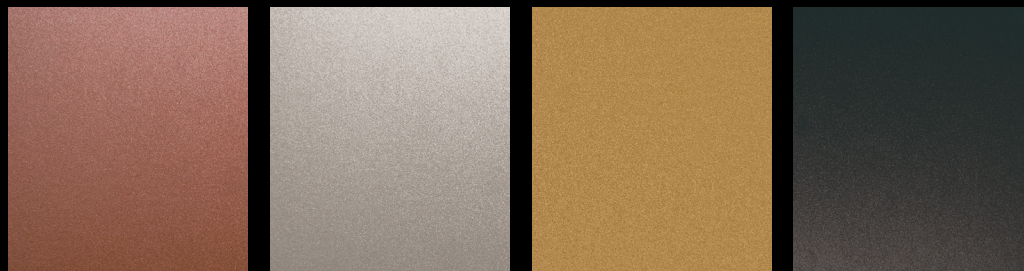

Bronzo  
*Bronze*

Nickel  
*Nickel*

Ottone  
*Brass*

Piombo  
*Lead*

### (B) Acidati *Etched*



Brunito  
*Burnished*

Corten  
*Corten*

Bronzato  
*Bronzed*

### (C) Fusione di alluminio *Cast Aluminum*

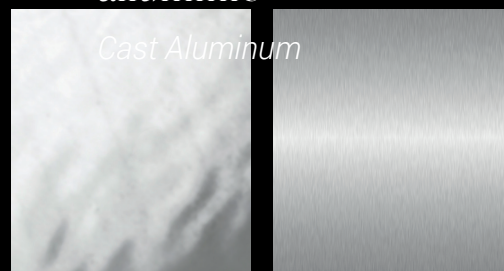

Lucido  
*Glossy*

Spazzolato  
*Frosted*

### (P) Verniciati a polveri *Powder Coating*



Nero  
*Black*

Antracite  
*Anthracite*

Bianco  
*White*

Artic  
*Artic lichen*

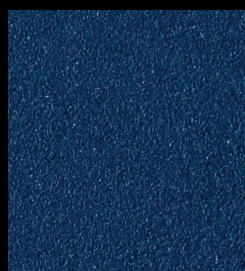

Blue oceano  
*Blue Oce*



Corten  
*Corten*



Bronzato  
*Bronzato*



Rosso mosto  
*Red must*

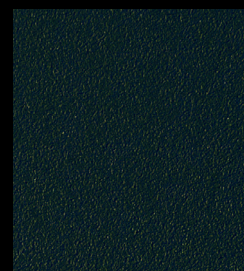

Verde Amazzonia  
*Green Amazon*

# Legno e Argille Wood and Clay

## Ⓔ Legni massellati

*Veneered and Solid Wood Edge*

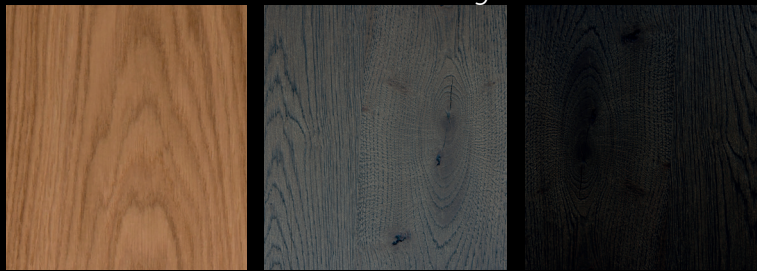

Rovere  
*Oak*

Rovere silver  
*Silver Oak*

Rovere nero  
*Black Oak*

## Ⓕ Legni impiallacciati

*Wood Veneered*



Noce canaletto  
*Canaletto Walnut*

Rovere  
*Oak*

Rovere silver  
*Silver Oak*

Rovere nero  
*Black Oak*

## Ⓖ Argille biocompatibili

*Clay biocompatible*



Antracite  
*Anthracite*

Bianco  
*White*

Smeraldo  
*Green Emerald*



Grigio tortora  
*Dove Grey*

Grigio elefante  
*Elephant Grey*

Terra Eritrea  
*Eritrea Soil*



NOTA

I campioni di colori e materiali hanno valore indicativo.



\_Elite To Be si riserva la facoltà di apportare modifiche o  
migliorie in qualsiasi momento, anche senza preavviso.  
I campioni di colori e materiali hanno valore indicativo.  
Tutti i diritti sono riservati.

*\_Elite To Be has the right to make changes or  
improvements at any time, even without notice.  
Printed color board are only a reference  
All rights reserved.*

o





Unicità in arredo

**ELITE TO BE S.r.l.**  
Viale Trento 59/a  
33077 Sacile (PN) - Italy  
Tel. +39.0434.781858  
info@elitetobe.it

elitetobe.it